

# CAT® C3.6

U.S. EPA TIER 4 FINAL/EU STAGE V/JAPAN 2014

55-106 kW (74-142 HP) @ 2000-2400 RPM



INDUSTRIAL

The Cat® C3.6 industrial diesel engine balances compact size, reliability, and performance. This engine is offered in ratings ranging up to 106 kW (142 hp) @ 2200 rpm.

The C3.6 is designed to meet the needs of many industries and applications including; agricultural tractors, bore/drill rigs, compactors/rollers, compressors, forestry, material handling, mining, earthmoving equipment, fruit harvesters and more.



## FEATURES AND BENEFITS

### RELIABLE POWER, HIGH PERFORMANCE

World-class manufacturing capability and processes coupled with proven technologies and extensive field validation assure reliability and durability in tough nonroad applications. Leading edge fuel systems and turbocharging provide high torque even at lower engine speeds.

### LOW COST MAINTENANCE

Worldwide service delivers ease of maintenance and simplifies the servicing routine. Capable of optimal oil change intervals of 500 hours. The S-O-S program is available from your Cat® dealer to determine oil change intervals and provide optimal performance.

### WORLD-CLASS PRODUCT SUPPORT

The global Cat dealer network provides support including; scheduled maintenance eg S-O-S sample, Customer Value Agreements (CVA), Extended Service Coverage (ESC), superior dealer service network and extended dealer service network through the Industrial Service Distributor (ISD) program.

### COMPACT AND FULLY CONFIGURABLE

The C3.6 is a compact engine with on engine aftertreatment offered for best value and simplest OEM design and manufacturing processes. Remote mount alternatives are also available. The engines are fully configurable to ensure they meet our customers specific needs.

## SPECIFICATION

Cylinders	4
Displacement, litres (in <sup>3</sup> )	3.6 (220.9)
Aspiration	Turbocharged aftercooled (TA)
Bore and stroke, mm (in)	98 x 120 (3.86 x 4.72)
Maximum torque, Nm (lb ft) @ rated speed, rpm	566 (417) @ 1500
Combustion system	Direct injection
Compression ratio	17:01
Aftertreatment	DOC+DPF or DOC+DPF+SCR
Total lubricating oil capacity, litres (US gal)	11.6 (3.06)
Rotation (viewed from flywheel)	Anti-clockwise
Length x width x height, mm (in)	667 x 564 x 787 (26.3 x 22.2 x 31.0)
Weight, kg (lb)	381 (840), dry 421 (928), wet

For additional information on all your power requirements, visit [www.cat.com/industrial](http://www.cat.com/industrial)

All information in this document is substantially correct at time of printing and may be altered subsequently. Photographs are for illustrative purposes only and may not reflect final specification. Final weight and dimensions will depend on completed specification. Information subject to selected configuration, and subject to change without notice. Engine power measured per ISO 14396:2002

AEXJ0162-01 (01-25)

© Caterpillar. All Rights Reserved. CAT, CATERPILLAR, LET'S DO THE WORK, their respective logos, "Caterpillar Corporate Yellow", the "Power Edge" and Cat "Modern Hex" trade dress as well as corporate and product identity used herein, are trademarks of Caterpillar and may not be used without permission.

# CAT® C3.6

U.S. EPA TIER 4 FINAL/EU STAGE V/JAPAN 2014

55-106 KW (74-142 HP) @ 2000-2400 RPM



INDUSTRIAL

## PERFORMANCE CURVES

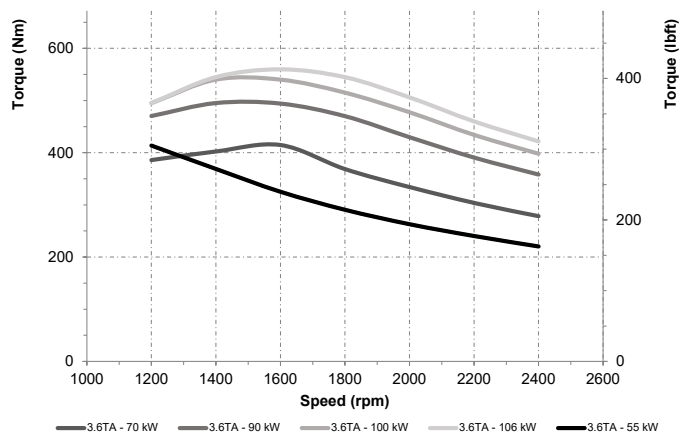
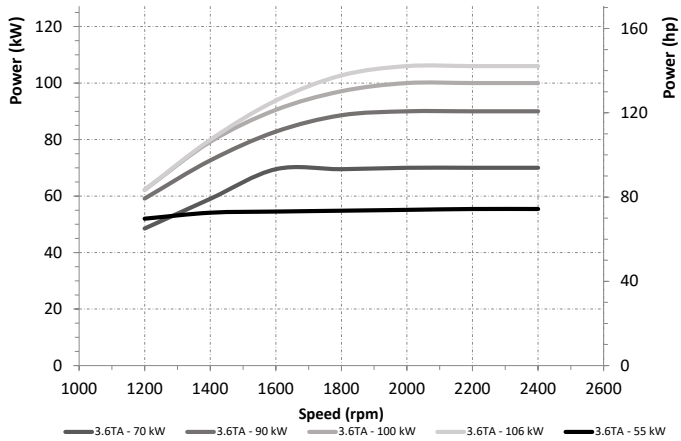

## DIMENSIONS

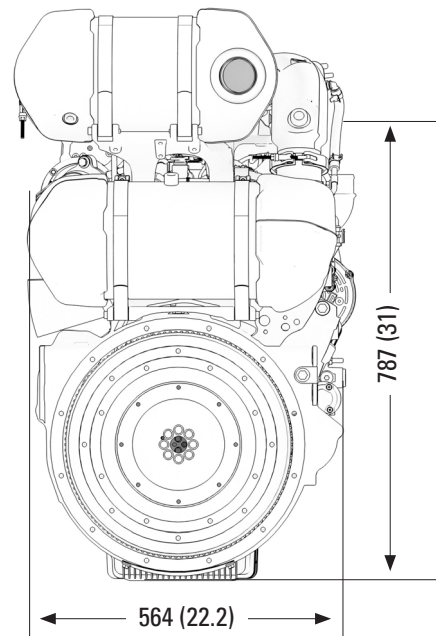
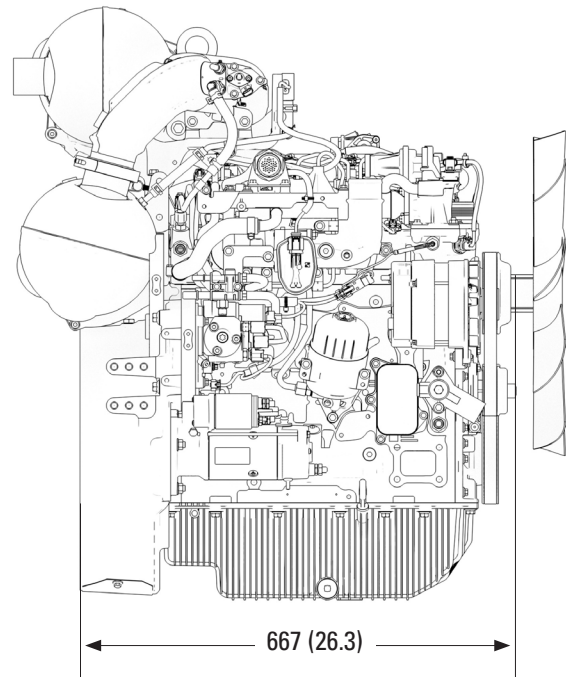

For additional information on all your power requirements, visit [www.cat.com/industrial](http://www.cat.com/industrial)

All information in this document is substantially correct at time of printing and may be altered subsequently. Photographs are for illustrative purposes only and may not reflect final specification. Final weight and dimensions will depend on completed specification. Information subject to selected configuration, and subject to change without notice. Engine power measured per ISO 14396:2002

AEXJ0162-01 (01-25)

© Caterpillar. All Rights Reserved. CAT, CATERPILLAR, LET'S DO THE WORK, their respective logos, "Caterpillar Corporate Yellow", the "Power Edge" and Cat "Modern Hex" trade dress as well as corporate and product identity used herein, are trademarks of Caterpillar and may not be used without permission.