

Cat® C32B

Diesel Generator Sets



Bore – mm (in)	145 (5.7)
Stroke – mm (in)	162 (6.4)
Displacement – L (in ³)	32.1 (1959)
Compression Ratio	15.0:1
Aspiration	TA
Fuel System	EUI
Governor Type	ADEM™ A4

Image shown may not reflect actual configuration.

Standby 60 Hz ekW (kVA)	Mission Critical 60 Hz ekW (kVA)	Prime 60 Hz ekW (kVA)	Continuous 60 Hz ekW (kVA)	Emissions Performance
1000 (1250)	1000 (1250)	910 (1137)	830 (1038)	U.S. EPA Certified for Emergency Stationary Applications (Tier 2)

Standard Features

Cat® Diesel Engine

- Meets U.S. EPA Emergency Stationary Use Only (Tier 2) emission standards
- Reliable and consistent performance proven in thousands of applications worldwide

Generator Set Package

- Accepts 100% block load in one step and meets NFPA 110 loading requirements
- Conforms to ISO 8528-5 G3 load acceptance requirements.
- Reliability is verified through prototype testing, which includes torsional vibration, fuel consumption, oil consumption, transient performance, and endurance testing

Alternators

- Superior motor starting capability minimizes the need for oversizing the generator
- Designed to match the performance and output characteristics of Cat diesel engines

Cooling System

- Cooling systems available to operate in ambient temperatures up to 50°C (122°F)
- Tested to ensure proper generator set cooling

EMCP 4 Control Panels

- User-friendly interface and navigation
- Multiple parameters are monitored & displayed simultaneously for full visibility
- The module can be configured to suit a wide range of applications for user flexibility

Warranty

- 24 months/1000-hour warranty for standby and mission critical ratings
- 12 months/unlimited hour warranty for prime and continuous ratings
- Complimentary 5-Year Platinum Cat® Extended Service Coverage (ESC) available on eligible products*

Worldwide Product Support

- Cat dealers have over 1,800 dealer branch stores operating in 200 countries
- Your local Cat dealer provides extensive post-sale support, including maintenance and repair agreements

Financing

- Caterpillar offers an array of financial products to help you succeed through financial service excellence
- Options include loans, finance lease, operating lease, working capital, and revolving line of credit
- Contact your local Cat dealer for availability in your region

Standard and Optional Equipment

Engine

Air Cleaner

- Single element
- Dual element
- Heavy duty

Muffler

- Industrial grade (15 dB)

Starting

- Standard batteries
- Oversized batteries
- Standard electric starter
- Dual electric starter
- Jacket water heater

Alternator

Output voltage

- 220V 480V
- 240V 600V
- 380V 2400V
- 400V 4160V

Temperature Rise (over 40°C ambient)

- 150 °C
- 125 °C/130 °C
- 105 °C
- 80 °C

Winding type

- Random wound
- Form wound

Excitation

- Self excited
- Internal excitation (IE)
- Permanent magnet (PM)

Attachments

- Anti-condensation heater
- Stator and bearing temperature monitoring and protection

Power Termination

Type

- Bus bar
- Circuit breaker
- 400A 800A
- 1200A 1600A
- 2000A 2500A
- 3000A 3200A
- IEC UL
- 3-pole 4-pole
- Manually operated
- Electrically operated

Trip Unit

- LSI LSI-G
- LSI-G-P

Factory Enclosure

- Weather protective
- Sound attenuated

Attachments

- Cold weather bundle
- DC lighting package
- AC lighting package
- Motorized louvers

Fuel Tank

Controller

- Sub-base
- 1000 gal (3785 L)
- 2000 gal (7571 L)
- 3600 gal (13627 L)

Control System

Controller

- EMCP 4.2B
- EMCP 4.3
- EMCP 4.4

Attachments

- Local annunciator module
- Remote annunciator module
- Expansion I/O module
- Remote monitoring software

Charging

- Battery charger – 10A

Vibration Isolators

- Rubber
- Spring
- Seismic rated

Telematics

Connectivity

- Ethernet
- Cellular
- Satellite

Extended Service Options

Terms

- 2 year (prime)
- 3 year
- 5 year
- 10 year

Coverage

- Silver
- Gold
- Platinum
- Platinum Plus

Ancillary Equipment

- Automatic transfer switch (ATS)
- Uninterruptible power supply (UPS)
- Paralleling switchgear
- Paralleling controls

Certifications

- UL 2200 Listed
- CSA
- IBC seismic certification
- OSHPD pre-approval

Note: Some options may not be available on all models. Certifications may not be available with all model configurations. Consult factory for availability.

Package Performance

Performance	Standby		Mission Critical		Prime		Continuous	
Frequency	60 Hz		60 Hz		60 Hz		60 Hz	
Gen set power rating with fan	1000 ekW		1000 ekW		910 ekW		830 ekW	
Gen set power rating with fan @ 0.8 power factor	1250 kVA		1250 kVA		1138 kVA		1038 kVA	
Emissions	EPA ESE (Tier 2)		EPA ESE (Tier 2)		EPA ESE (Tier 2)		EPA ESE (Tier 2)	
Performance number	EM7600		EM7649		EM7630		EM7626	
Fuel Consumption								
100% load with fan – L/hr (gal/hr)	272.1	(71.9)	272.1	(71.9)	248.6	(65.7)	232.1	(61.3)
75% load with fan – L/hr (gal/hr)	213.4	(56.4)	213.4	(56.4)	197.0	(52.0)	176.5	(46.6)
50% load with fan – L/hr (gal/hr)	144.7	(38.2)	144.7	(38.2)	134.2	(35.5)	122.9	(32.5)
25% load with fan – L/hr (gal/hr)	82.6	(21.8)	82.6	(21.8)	78.5	(20.7)	73.4	(19.4)
Cooling System								
Radiator air flow restriction (system) – kPa (in. water)	0.12	(0.48)	0.12	(0.48)	0.12	(0.48)	0.12	(0.48)
Radiator air flow – m ³ /min (CFM)	1175	(41494)	1175	(41494)	1175	(41494)	1175	(41494)
Engine coolant capacity – L (gal)	55.0	(14.5)	55.0	(14.5)	55.0	(14.5)	55.0	(14.5)
Radiator coolant capacity – L (gal)	36.0	(9.0)	36.0	(9.0)	36.0	(9.0)	36.0	(9.0)
Total coolant capacity – L (gal)	91.0	(23.5)	91.0	(23.5)	91.0	(23.5)	91.0	(23.5)
Inlet Air								
Combustion air inlet flow rate – m ³ /min (CFM)	87.6	(3094.1)	87.6	(3094.1)	83.7	(2954.5)	80.0	(2825.6)
Exhaust System								
Exhaust stack gas temperature – °C (°F)	476.4	(889.5)	476.4	(889.5)	459.5	(859.1)	461.2	(862.1)
Exhaust gas flow rate – m ³ /min (CFM)	228.4	(8065.3)	228.4	(8065.3)	212.1	(7488.7)	204.8	(7231.2)
Exhaust system backpressure (maximum allowable) – kPa (in. water)	6.7	(27.0)	6.7	(27.0)	6.7	(27.0)	6.7	(27.0)
Heat Rejection								
Heat rejection to jacket water – kW (BTU/min)	352	(20033)	352	(20033)	327	(18624)	307	(17468)
Heat rejection to exhaust (total) – kW (BTU/min)	1024	(58206)	1024	(58206)	933	(53072)	896	(50940)
Heat rejection to aftercooler – kW (BTU/min)	288	(16385)	288	(16385)	255	(14526)	230	(13082)
Heat rejection to atmosphere from engine – kW (BTU/min)	127	(7238)	127	(7238)	116	(6625)	114	(6486)
Heat rejection from alternator – kW (BTU/min)	55	(3131)	55	(3131)	50	(2846)	45	(2561)
Emissions* (Nominal)								
NOx mg/Nm ³ (g/hp-h)	2348.6	(4.93)	2348.6	(4.93)	2293.5	(4.81)	1969.0	(4.23)
CO mg/Nm ³ (g/hp-h)	62.1	(0.13)	62.1	(0.13)	59.2	(0.12)	52.5	(0.11)
HC mg/Nm ³ (g/hp-h)	5.5	(0.01)	5.5	(0.01)	7.0	(0.02)	12.7	(0.03)
PM mg/Nm ³ (g/hp-h)	7.2	(0.02)	7.2	(0.02)	6.6	(0.02)	7.1	(0.02)
Emissions* (Potential Site Variation)								
NOx mg/Nm ³ (g/hp-h)	2841.6	(5.97)	2841.6	(5.97)	2775.2	(5.83)	2382.5	(5.11)
CO mg/Nm ³ (g/hp-h)	116.1	(0.24)	116.1	(0.24)	110.6	(0.23)	98.1	(0.21)
HC mg/Nm ³ (g/hp-h)	10.3	(0.03)	10.3	(0.03)	13.2	(0.03)	24.1	(0.06)
PM mg/Nm ³ (g/hp-h)	14.1	(0.04)	14.1	(0.04)	12.9	(0.03)	13.9	(0.04)

*mg/Nm³ levels are corrected to 5% O₂. Contact your local Cat dealer for further information.

Weights and Dimensions

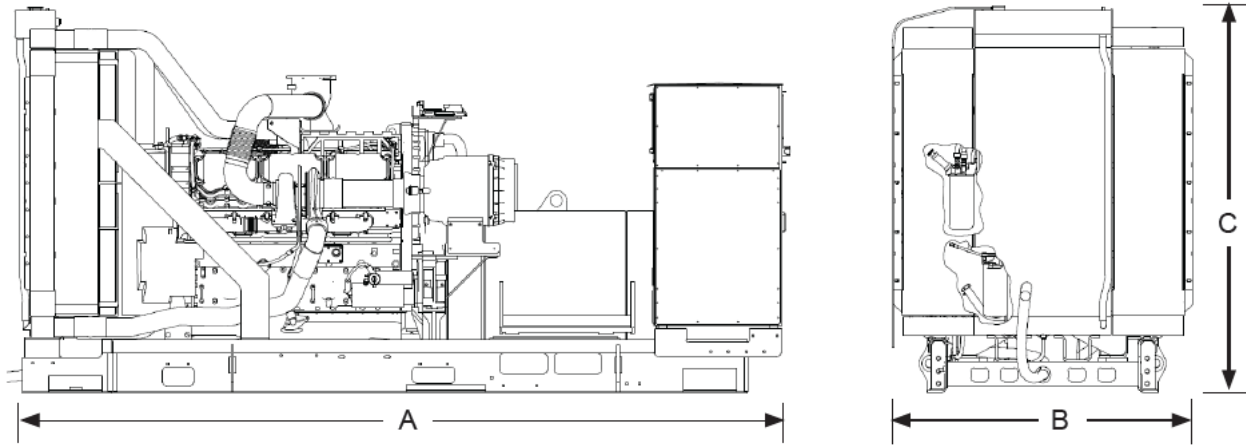

Dim "A" mm (in)	Dim "B" mm (in)	Dim "C" mm (in)	Dry Weight kg (lb)
4165 (164.0)	1684 (66.3)	2162 (85.1)	6668 (14,700)

Note: For reference only. Do not use for installation design. Contact your local Cat dealer for precise weights and dimensions.

Ratings Definitions

Standby: Output available with varying load for the duration of the interruption of the normal source power. Average power output is 70% of the standby power rating. Typical operation is 200 hours per year, with maximum expected usage of 500 hours per year.

Mission Critical: Output available with varying load for the duration of the interruption of the normal source power. Average power output is 85% of the mission critical power rating. Typical peak demand up to 100% of rated power for up to 5% of the operating time. Typical operation is 200 hours per year, with maximum expected usage of 500 hours per year.

Prime: Output available with varying load for an unlimited time. Average power output is 70% of the prime power rating. Typical peak demand is 100% of prime rated kW with 10% overload capability for emergency use for a maximum of 1 hour in 12. Overload operation cannot exceed 25 hours per year.

Continuous: Output available with non-varying load for an unlimited time. Average power output is 70-100% of the continuous power rating. Typical peak demand is 100% of continuous rated kW for 100% of the operating hours.

Fuel Rates

Fuel rates are based on fuel oil of 35° API [16°C (60°F)] gravity having an LHV of 42,780 kJ/kg (18,390 Btu/lb) when used at 29°C (85°F) and weighing 838.9 g/liter (7.001 lbs/U.S. gal.)

Applicable Codes and Standards

CSA C22.2 No 100-04, UL489, UL 2200, IBC, IEC 60034-1, ISO 3046, ISO 8528, NEMA MG1-22, NEMA MG1-33, and facilitates compliance to NFPA 37, NFPA 70, NFPA 99, NFPA 110.

Note: Codes may not be available in all model configurations. Please consult your local Cat dealer for availability.

Data Center Applications

- ISO 8528-1 Data Center Power (DCP) compliant per DCP application of Cat diesel generator set prime power rating.
- All ratings Tier III/Tier IV compliant per Uptime Institute requirements.
- All ratings ANSI/TIA-942 compliant for Rated-1 through Rated-4 data centers.

* Coverage subject to terms and conditions. Eligibility criteria and program availability subject to change without notice. No additional warranty, representation, or obligation, express or implied, is created or extended beyond those expressly set forth in the relevant ESC terms.

www.cat.com/electricpower

©2026 Caterpillar

All rights reserved.

Materials and specifications are subject to change without notice.

The International System of Units (SI) is used in this publication. CAT, CATERPILLAR, LET'S DO THE WORK, their respective logos, "Caterpillar Corporate Yellow", the "Power Edge" and Cat "Modern Hex" trade dress as well as corporate and product identity used herein, are trademarks of Caterpillar and may not be used without permission.