

Cat® C32B

Diesel Generator Sets



Image shown might not reflect actual configuration.

Engine	C32B
Bore – mm (in)	145 (5.7)
Stroke – mm (in)	162 (6.4)
Displacement – L (in ³)	32.1 (1959)
Compression Ratio	14.0:1
Aspiration	TA
Fuel System	EUI
Governor Type	ADEM™ A4

Model	Standby / Mission Critical 50 Hz kVA (eKW)	Emissions Performance
DE1400 GC	1400 (1120)	Optimized for Low Fuel Consumption

Standard Features

Cat® Diesel Engine

- Designed and optimized for low fuel consumption
- Industry-leading mechanical and electrical design
- Industry-leading motor starting capabilities
- High efficiency

Generator Set Package

- Conforms to ISO8528-5 G3 load acceptance requirements
- Reliability is verified through prototype testing, which includes torsional vibration, fuel consumption, oil consumption, transient performance, and endurance testing

Alternators

- Superior motor starting capability minimizes the need for oversizing the generator
- Designed to match the performance and output characteristics of Cat diesel engines

Cooling System

- Cooling systems available to operate in ambient temperatures 50°C @ 0 m (To be validated)
- Tested to ensure proper generator set cooling

GCCP Control Panels

- User-friendly set-up and button layout for ease of use
- Multiple parameters are monitored & displayed simultaneously for full visibility
- The module can be configured to suit a wide range of applications for user flexibility

Warranty

- 24 months/1000-hour warranty for standby and mission critical ratings
- Extended service protection is available to provide extended coverage options

Worldwide Product Support

- Cat dealers have over 1,800 dealer branch stores operating in 200 countries
- Your local Cat dealer provides extensive post-sale support, including maintenance and repair agreements

Financing

- Caterpillar offers an array of financial products to help you succeed through financial service excellence
- Options include loans, finance lease, operating lease, working capital, and revolving line of credit
- Contact your local Cat dealer for availability in your region

Standard and Optional Equipment

Engine

Air Cleaner

- Single element
- Dual element

Starting

- Standard batteries
- Jacket water heater

Engine Attachments

- Manual Sump Pump
- Fuel Transfer Pump
(With fuel tank base only)
- 6" Exhaust Flexible Fittings
- 6" Exhaust Flange Kits

Alternator

Output voltage

- 400V
- 415V

Temperature Rise (over 40°C ambient)

- 150°C

Winding type

- Random wound

Excitation

- Internal excitation (IE)
- Permanent magnet (PM)

Attachments

- Anti-condensation heater

Power Termination

Type

- Power Terminal Strips
- Circuit breaker
- 2500A
- 3-pole 4-pole
- Manually operated
- Electrically operated

Factory Enclosure

- Sound attenuated

Attachments

- DC lighting package

Fuel Tank

- 1000 L (264 gal)
(With enclosure only)

Control System

Controller

- GCCP 1.3
- GCCP 1.4

Attachments

- Ground Fault Indication

Charging

- Battery charger – 10A

Telematics

Connectivity

- Ethernet
- Cellular

Extended Service Options

Terms

- 3 year
- 4 year
- 5 year

Coverage

- Silver
- Gold

Certifications

- CE
- EAC
- UKCA

Note: Some options may not be available on all models. Certifications may not be available with all model configurations. Consult factory for availability.

Package Performance – DE1400 GC

Performance	Standby		Mission Critical	
Frequency	50 Hz		50 Hz	
Genset power rating with fan	1120 ekW		1120 ekW	
Genset power rating with fan @ 0.8 power factor	1400 kVA		1400 kVA	
Fueling strategy	Low Fuel Consumption		Low Fuel Consumption	
Performance number	EM7476		EM7483	
Fuel Consumption				
100% load with fan – L/hr (gal/hr)	292.1	(77.2)	292.1	(77.2)
75% load with fan – L/hr (gal/hr)	217.4	(57.4)	217.4	(57.4)
50% load with fan – L/hr (gal/hr)	149.4	(39.5)	149.4	(39.5)
25% load with fan – L/hr (gal/hr)	87.9	(23.2)	87.9	(23.2)
Cooling System				
Radiator air flow restriction (system) – kPa (in. water)	0.12	(0.48)	0.12	(0.48)
Radiator air flow – m ³ /min (CFM)	1101	(38881)	1101	(38881)
Engine coolant capacity – L (gal)	55	(14.5)	55	(14.5)
Radiator coolant capacity – L (gal)	61	(16.1)	61	(16.1)
Total coolant capacity – L (gal)	116	(30.6)	116	(30.6)
Inlet Air				
Combustion air inlet flow rate – m ³ /min (CFM)	95.5	(3372.4)	95.5	(3372.4)
Exhaust System				
Exhaust stack gas temperature – °C (°F)	424.9	(796.8)	424.9	(796.8)
Exhaust gas flow rate – m ³ /min (CFM)	231.7	(8179.8)	231.7	(8179.8)
Exhaust system backpressure (maximum allowable) – kPa (in. water)	6.7	(27.0)	6.7	(27.0)
Heat Rejection				
Heat rejection to jacket water – kW (BTU/min)	378	(21495)	378	(21495)
Heat rejection to exhaust (total) – kW (BTU/min)	977	(55537)	977	(55537)
Heat rejection to aftercooler – kW (BTU/min)	341	(19408)	341	(19408)
Heat rejection to atmosphere from engine – kW (BTU/min)	195	(11114)	195	(11114)
Heat rejection from alternator – kW (BTU/min)	52.8	(3003)	52.8	(3003)
Emissions* (Nominal)				
NO _x mg/Nm ³ (g/hp-h)	2630.3	(5.65)	2630.3	(5.65)
CO mg/Nm ³ (g/hp-h)	71.8	(0.15)	71.8	(0.15)
HC mg/Nm ³ (g/hp-h)	7.6	(0.003)	7.6	(0.003)
PM mg/Nm ³ (g/hp-h)	6.5	(0.015)	6.5	(0.015)
Emissions* (Potential Site Variation)				
NO _x mg/Nm ³ (g/hp-h)	3182.6	(6.83)	3182.6	(6.83)
CO mg/Nm ³ (g/hp-h)	134.3	(0.27)	134.3	(0.27)
HC mg/Nm ³ (g/hp-h)	14.5	(0.04)	14.5	(0.04)
PM mg/Nm ³ (g/hp-h)	12.7	(0.03)	12.7	(0.03)

*mg/Nm³ levels are corrected to 5% O₂. Contact your local Cat dealer for further information.

Weights and Dimensions

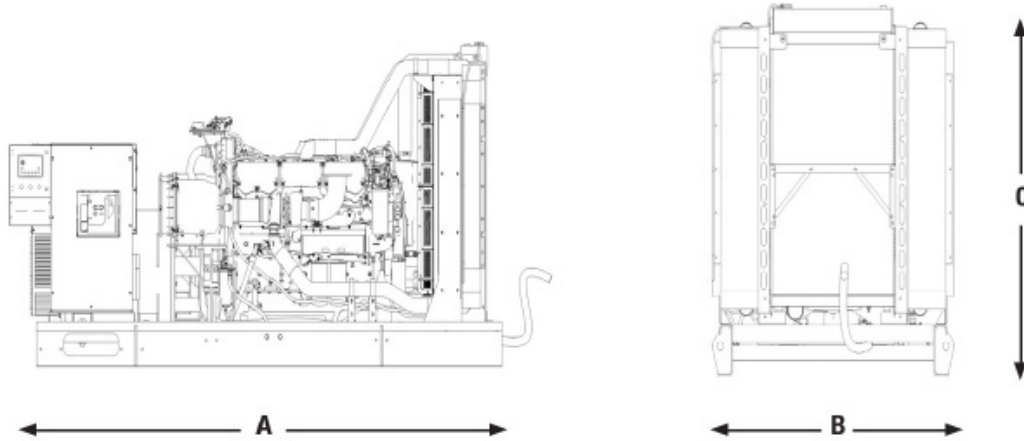

Length "A" mm (in)	Width "B" mm (in)	Height "C" mm (in)	Wet Weight kg (lb)
4175 (164.3)	2090.5 (82.3)	2268 (89.3)	7436 (16393)

Note: For reference only. Do not use for installation design. Contact your local Cat dealer for precise weights and dimensions.

Ratings and Definitions

Standby

Output available with varying load for the duration of the interruption of the normal source power. Average power output is 70% of the standby power rating. Typical operation is 200 hours per year, with maximum expected usage of 500 hours per year.

Mission Critical

Output available with varying load for the duration of the interruption of the normal source power. Average power output is 85% of the mission critical power rating. Typical peak demand up to 100% of rated power for up to 5% of the operating time. Typical operation is 200 hours per year, with maximum expected usage of 500 hours per year.

Applicable Codes and Standards

AS1359, IEC 60034-1, ISO 3046, ISO 8528, 2014/35/EU, 2006/42/EC, 2014/30/EU, 2008 No. 1597, 2016 No. 1091, 2016 No. 1101 and 2001 No. 1701 amended by 2005 No. 3525.

Note: Codes may not be available in all model configurations. Please consult your local Cat dealer for availability.

Fuel Rates

Fuel rates are based on fuel oil of 35° API [16°C (60°F)] gravity having an LHV of 42,780 kJ/kg (18,390 Btu/lb) when used at 29°C (85°F) and weighing 838.9 g/liter (7.001 lbs/U.S. gal.)

www.cat.com/electricpower

©2026 Caterpillar
 All rights reserved.

Materials and specifications are subject to change without notice.

The International System of Units (SI) is used in this publication. CAT, CATERPILLAR, LET'S DO THE WORK, their respective logos, "Caterpillar Corporate Yellow", the "Power Edge" and Cat "Modern Hex" trade dress as well as corporate and product identity used herein, are trademarks of Caterpillar and may not be used without permission.