



Cat® Energy Control System (ECS) 200

The Cat ECS 200 generator set controller uses system graphic icons and labels that allow for simple, comprehensive multiple generator set paralleling operation. The easy-to-use 203 mm (8") color LED touchscreen display features scroll navigation. Generator set and remote-mount options are available.

Image shown may not reflect actual configuration.

FEATURES

- Island mode – Up to 32 generator sets with Cat ECS 200 control systems
- High visibility graphical touchscreen display with alarm/event descriptions, set points, engine and generator monitoring
- Meets UL 2200, 3rd Edition requirements including UL 6200
- Local annunciation to meet NFPA 110 (subject to local authority having jurisdiction approval)
- Ethernet Modbus TCP for external communications
- Intuitive navigation for display of power metering, protection, engine and generator parameters and tuning
- Lockout security provision to assure platform integrity with three programable security levels
- Support of up to four (4) remote HMI's (sold separately)
- Multi-language support
- Compatibility with Cat VisionLink™ devices
- IVR or CDVR voltage regulation compatibility
- Emergency Override

Advanced Functionality

- Automatic mains failure w/ utility voltage sensing capability (open transition) and remote breaker or contactor control/monitoring
- Engine remote start signal integrity monitoring
- Generator circuit breaker control
- Single gen Transient Load Relief (TLR)
- Basic programmable logic control (PLC) function
- Base load w/utility featuring genset circuit breaker (GCB) control
- Embedded webserver
- EPA Tier 4 integration
- Real (kW) load histograms
- Status event logs
- Supports Dynamic Gas Blending
- Dead bus arbitration
- Failsafe Adaptive Load Sharing/Droop Operation
- Balance of Plant (BoP) including Combined Heat and Power (CHP) option
- Grid Code option

Control Module and Display

The Cat ECS 200 utilizes two Cat A6L3 modules and a high-resolution display for the human machine interface (HMI) for single generator set or paralleling applications.



Examples of Typical⁽¹⁾ Single Line Diagram (SLD)

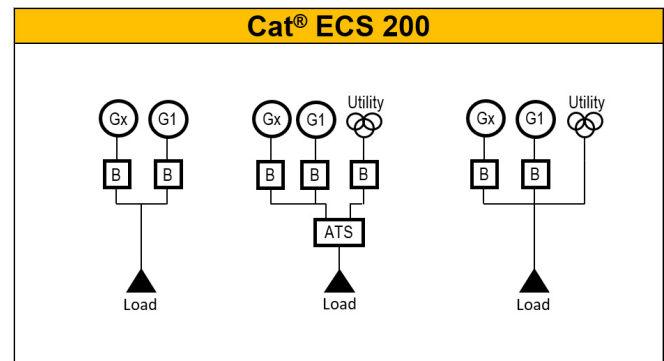

⁽¹⁾ – More single line diagrams (SLD's) are available to meet application requirements. Contact your local Cat dealer for more information.

Standard Features

Controls	<ul style="list-style-type: none"> • Auto / Start / Stop • Emergency stop • Engine cooldown timer • Engine cycle crank • Programmable cycle timer • Speed and voltage adjust
Generator Set Monitoring	<ul style="list-style-type: none"> • Generator AC voltage monitoring (+/- 0.25% controller lifetime accuracy) • Utility/Bus AC voltage monitoring (+/- 0.25% controller lifetime accuracy) • 3 phase/4 wire (L-L&L-N) sensing • Current sensing (3 phase/6 wire) (+/- 0.1% up to 100% of rated current controller accuracy) • Generator AC current (per phase & avg) • Generator frequency • Power metering (kW, kVA, kVAr, pf) • kW-hr (export), kVAr-hr (import and export), total and trip • Generator stator and bearing temp (with optional RTD module) • kW load histogram
Generator Protection	<ul style="list-style-type: none"> • Generator phase sequence (47G) • Over/Under voltage (27/59) • Over/Under frequency (81 O/U) • Instantaneous and inverse time (50/51) • Overcurrent (Thermal Damage Curve) (51) • Reverse power real (kW) (32) • Reverse power reactive (kVAr) (32RV) • Current balance (46) • Overload (49)
Engine Monitoring	<ul style="list-style-type: none"> • Engine oil pressure (kPa or psi) • Engine oil temperature (°C or °F) • Engine coolant temperature (°C or °F) • Engine speed (RPM) • Battery voltage • Crank attempt and successful start counter • Run hour meter • Real time clock
Engine Protection	<ul style="list-style-type: none"> • Control switch not in auto (alarm) • Low oil pressure • High coolant temperature (alarm and shutdown) • Low coolant temp (alarm) • Low coolant level (alarm and shutdown) • High engine oil temp (alarm and shutdown) • Low/High/Weak battery voltage • Fail to start • Overspeed • Overcrank • Low gas pressure (alarm and shutdown)

Standard Features *(continued)*

Digital Inputs	<ul style="list-style-type: none"> • Emergency Stop • Remote Start • Group Start • 32 programmable inputs (4 used for functional safety)⁽²⁾
Digital Outputs	<ul style="list-style-type: none"> • 24 programmable outputs (4 used for functional safety)⁽²⁾
Analog Output	<ul style="list-style-type: none"> • 4 analog outputse (46)
PWM Outputs	<ul style="list-style-type: none"> • 6 programmable inputs (0-5V, 0.5-4.5V, 1-5V, or resistive)⁽²⁾
Analog Inputs	<ul style="list-style-type: none"> • Primary & accessory CAN data link • Remote annunciator data link up to 1219 m (4000 ft) • Cat® Data Link (CDL) – with optional PLE702 • Ethernet (Modbus TCP/IP) – 100 baseT • USB- touchscreen display • Eight 4-wire ports for internal and customer use • Four 2-wire ports for internal device network
Communication	<ul style="list-style-type: none"> • Primary & accessory CAN data link • Remote annunciator data link up to 1219 m (4000 ft) • Cat® Data Link (CDL) – with optional PLE702 • Ethernet (Modbus TCP/IP) – 100 baseT • USB- touchscreen display • Eight 4-wire ports for internal and customer use • Four 2-wire ports for internal device network
Environmental	<ul style="list-style-type: none"> • HMI (front touchscreen) IP66 • A6L3 Controller Operating Temp. -40°C to + 70°C • Control module box: <ul style="list-style-type: none"> – Ingress protection IP23 – Health Care Access and Information (HCAI) ground and roof seismic certification
Languages	<ul style="list-style-type: none"> • Chinese Danish English French German Italian Japanese Portuguese Russian Spanish additional languages on request

⁽²⁾ – Generator set configuration may affect available features.

Enhanced Control Features

Advanced overcurrent protection

The Cat ECS 200 provides advanced overcurrent protection of the generator set system via programmable Definite Time and Inverse Time curves.

For the Inverse time curve the following four selections are available:

- Normally Inverse
- Very Inverse
- Extremely Inverse
- Thermal Damage Curve – the Thermal Damage curve may be more closely aligned to specific generators.

Arc Flash Maintenance mode

The Cat ECS 200 Programmable Arc Flash Energy Reducing Maintenance Mode feature provides a method to reduce clearing time via two functions that work together to meet the 2023 edition of NFPA 70, Section 240.87 (Arc Energy Reduction).

- A means to accept an energy-reducing maintenance switch and provide means to connect a local status indicator
- An instantaneous overcurrent setting that can be set below the available arcing current.

Integrated programmable logic controller (PLC)

This feature set of the Cat ECS 200 allows the user to create custom logic functions in similar fashion to that of the capability of a PLC controller. These logic functions allow for increased capability of the Cat ECS 200 through interaction and control of internal signals within the control software as well as the programmable inputs/ outputs of the device.

Programmable kW relay

The Cat ECS 200 includes three programmable kW relay outputs configured based on the % kW of the generator set. The configurable set points of the kW relay include: trigger condition, percentage threshold, hysteresis percentage and trip activation & deactivation delay time. These output functions may also be used to trigger events, recordable within the event log and included in the remote monitoring of the generator set.

Real-time clock

The real-time clock allows for date and time stamping of diagnostics and events in the control's logs as well as service maintenance reminders based on engine operating hours or calendar days.

Diagnostic System and Status Event Logs

Up to 40 unique diagnostic events (e.g., warnings, shutdowns, etc.) are stored in the non-volatile memory of each A6L3. It also allows for the creation of a status event log for each A6L3. Each log holds the last 500 control events such as Engine Control Switch Position, Remote Initiate, Load Shed, etc.

Events are stored in a "first in, first out" strategy.

Programmable cycle timer

The programmable cycle timer (PCT) feature allows for programming of seven independent times, when tasks (called PCT outputs), will be activated or deactivated automatically during the week. This is useful for exercising generator sets, or cases where two or more generators are required to automatically share the duty of supplying a load throughout the week. Using the PCT, each generator set can be programmed to start and stop at pre-set times. The PCT can handle a seven-day sequence with seven independent starts happening one or more times each week. Each of the seven timers has the following set points: activation day of the week, activation start time, active time and includes three (3) independent activation outputs.

Real (kW) load histogram

The Cat ECS 200 is equipped with a real (kW) load histogram. This feature keeps track of the amount of time the generator percent kW is within certain predefined ranges. The ranges monitored are in 10% steps (0 to <10%, 10% to <20%, ..., 90% to 100%).

Paralleling Functions

Advanced Paralleling Control Data Link (APCDL) or Multiple Generator Data Link (MGDL)

These configurations utilize an Ethernet-based communication protocol to accomplish a synchronizing and paralleling function between generator sets¹. APCDL functions between Cat ECS 200 controllers (maximum of 32 devices) while MGDL functions between Cat ECS 200 and EMCP 4.4 controllers (maximum of 16 devices)².

¹ The APCDL and MGDL communication protocols are mutually exclusive and can NOT co-exist on the Cat ECS 200 controller. Switching requires a controller software flash.

² Certain Cat ECS 200 features will be unavailable when operating with the MGDL communication protocol software files. Please refer to Special Instruction M0185838 for installation details and a list of the key feature differences.

Dead Bus Arbitration

The Cat ECS 200 incorporates true dead bus arbitration to determine and select the primary generator set to close to a dead bus, allowing only one unit to close to the dead bus. The dead bus arbitration control minimizes the time for the first generator set to close to the dead bus.

Synchronizing

The Cat ECS 200 monitors all three phases of the generator and main bus. The proprietary synchronizing algorithms drive the generator output frequency, voltage, and phase to match another source, and close the GCB when conditions for synchronizing have been met.

Load Shed/Load Add

The Cat ECS 200 provides a configurable load add signal as generator set capacity becomes available. In the event of generator capacity becoming unavailable during operation, a configurable load shed signal is provided. Enhanced load shed/load add capability is available with the feeder breaker control option.

Load sharing

The Cat ECS 200 actively monitors the real (kW) and reactive (kVAr) load requirement of all paralleled generator sets and adjusts output of the generator set to maintain a balanced loading of all generator sets.

Soft Load/Unload

When load sharing, soft loading and soft unloading reduces instability and risk to the equipment by increasing or decreasing load in a controlled manner before closing or opening the GCB.

Load Sense/Load Demand (LSLD)

This feature is the control scheme used to automatically bring generator sets onto the bus or take generator sets off the bus to serve facility loads while maintaining fuel efficiency and adequate reserve. The LSLD control algorithm analyzes system load levels, sequences priority assignments and generator status communicated via the APCDL network.

Feeder Breaker Control

Feeder breaker control for connecting a generator bus and a load bus is included with the Cat ECS 200 operation. For this feature set, a programmable digital output is configured for a “Feeder Breaker Close Command” and/or “Feeder Breaker Trip Command” based on minimum real/reactive power required setpoints. The advanced programming capability of this feature allows for the controlled sequencing of multiple load shed/add stages.

Modes of Operation

- **Automatic Paralleling**
In the automatic paralleling mode, the Cat ECS 200 controller automatically adjusts the voltage and frequency of the generator set. When the generator output is synchronized with the second source, the controller closes the GCB.
- **Manual Paralleling**
In the manual paralleling mode, the operator will manually adjust the voltage and frequency of the generator set. When the generator set is synchronized with the second source, the operator will initiate a generator circuit breaker close command. A 3-phase sync check function is also included to prevent out of phase paralleling.
- **Sync Check Mode**
In the sync check mode, the Cat ECS 200 controller automatically adjusts the voltage and frequency of the generator set without closing the GCB. When the generator set is synchronized with the second source, the operator will initiate a generator circuit breaker close command. A 3-phase sync check function is also included to prevent out of phase paralleling.

Failsafe Adaptive Load Sharing/Droop Operation

The Cat ECS 200 safely maintains stability through a loss of communication, seamlessly transitioning into failsafe mode with gradual, stable movement to a new equilibrium point.

Operation Moduels

Expansion Input/Output Ethernet Modules

- Supports expanded Inputs/Outputs (I/O) capability of the Cat ECS 200 control:
 - Analog & digital I/O
 - Temperature sensing (RTD)
- Configure I/O for any event (read & write function)

See LEHE22466

Modbus Coupler

Digital & Analog I/O

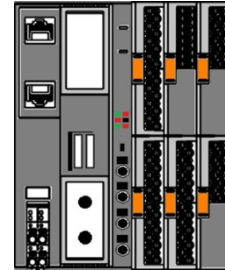

Balance of Plant (BoP)⁽³⁾

The Cat ECS 200 supports the control and monitoring of the components and auxiliary systems required for a genset to operate; this includes cooling system and ventilation control up to a full containerized Combined Heat and Power (CHP) containerized system.

See LEXE23122

Choice of Ethernet I/O module (ship loose):

- Jacket Water (JW) and Separate Circuit Aftercooler (SCAC) cooling
- Container Ventilation (CV) and Combined Heat and Power (CHP)
- Or both options (a) and (b)

Grid Code⁽⁴⁾

The Cat ECS 200 supports technical requirements for rules set by individual countries and that must be met by generating units and facility owners to gain permission to access the utility grid.

See LEXE23121

Grid codes specify technical requirements in several key areas:

- Frequency and voltage operating ranges
- Fault ride through
- Frequency support functions (real power control)
- Voltage support functions (reactive power control)
- Protection functions
- Inter-operability / remote communication and control (by grid operator)

Grid Codes Supported^{(5) (6)}

USA	IEEE 1547:2018
European Standard	EN 50549-2
Germany-MV	VDE-AR-N 4110
Germany-HV	VDE-AR-N 4120
Great Britain	G99 (Amendment 9)
Italy-MV	CEI 0-16:2022-03 V1
Italy-HV	Terna Codice di Trasmissione, Dispacciamento, Sviluppo e Sicurezza della Rete
Belgium	C10/11 ed. 2.2
Poland	Wymogi ogólnego stosowania
Netherlands	Netcode Elektriciteit
Romania	Ord. 72/2017, Ord. 214/2018
Spain	TED/749/2020
France	Arrêté du 9 juin 2020
Czech Republic	Příloha č.4 PPDS 2018
Greece	RAE Decision 1165/2020
Ireland	Distribution Code Version 8.0

⁽³⁾ – Expansion Module functionality with SEA (Software Enabled Attachment – sold separately).

Operation Moduels (continued)

Off Package HMI

- The Cat ECS 200 supports up to four (4) optional full function off package HMI displays with the addition of an unmanaged Ethernet switch. The interactive 203 mm (8") color touchscreen graphical interface serves to display generator set system alarm conditions, status indications and annunciation (with RCA output) to meet NFPA110 (subject to local authority having jurisdiction approval).



RS-485 Remote Annunciator

The Digital Input/Output (DI/O) module serves to provide expandable Input and Output for any event and is capable of reading 12 discrete inputs to trigger system events and setting 8 relay outputs based on system events. The DI/O module has been designed for use on the accessory communication network and may be used in either local (package mounted) or off package up to 244 m (800 feet) applications. A maximum of four DI/O modules may be used with a Cat ECS 200.

See LEHE21395



Digital Input/Output Module

The Digital Input/Output (DI/O) module serves to provide expandable Input and Output for any event and is capable of reading 12 discrete inputs to trigger system events and setting 8 relay outputs based on system events. The DI/O module has been designed for use on the accessory communication network and may be used in either local (package mounted) or off package up to 244 m (800 feet) applications. A maximum of four DI/O modules may be used with a Cat ECS 200.

See LEHE21394



RTD Module

The RTD module serves to provide expandable generator temperature monitoring capability of the Cat ECS 200 control system and is capable of reading up to eight 2-wire, 3-wire and 4-wire RTD inputs. The RTD Module has been designed for use on the accessory communication network and may be used in either local (package mounted) or off package up to 244 m (800 feet) applications. A maximum of one RTD Module may be used with a Cat ECS 200.

See LEHE21396



Dimensions

Package-Mounted or Ship Loose (with harness)



Control Box Dimensions	A mm (in)	B mm (in)	C ⁽³⁾ mm (in)	Weight kg (lbs)
Cat ECS 200	1428 (56.23)	794 (31.27)	273 (10.73)	70 (154)

⁽³⁾ – Dimension including E-Stop button is 263 mm (10.35 in).

Worldwide Product Support

Cat dealers have over 1,800 dealer branch stores operating in 200 countries and offer extensive post-sale support including maintenance and repair agreements.

www.cat.com/electricpower

©2026 Caterpillar
All rights reserved.

Materials and specifications are subject to change without notice.

The International System of Units (SI) is used in this publication. CAT, CATERPILLAR, LET'S DO THE WORK, their respective logos, "Caterpillar Corporate Yellow" the "Power Edge" and Cat "Modern Hex" trade dress as well as corporate and product identity used herein, are trademarks of Caterpillar and may not be used without permission.