

# Cat® C7.1

## Diesel Generator Sets



### Standby & Prime: 50 Hz & 60 Hz



Image shown might not reflect actual configuration.

Engine Model	Cat® C7.1 Inline 4-stroke Diesel
Bore x Stroke	105.0 mm x 135.0 mm (4.1 in x 5.3 in)
Displacement	7.0 L (427.8 in³)
Compression Ratio	16.0:1
Aspiration	Turbocharged Air To Air Charge Cooled
Fuel Injection System	Inline
Governor	Mechanical

Model	Standby		Prime		Emission Strategy
	50 Hz	60 Hz	50 Hz	60 Hz	
DE200E0	200.0 kVA (160.0 kW)	218.8 kVA (175.0 kW)	180.0 kVA (144.0 kW)	199.4 kVA (159.5 kW)	Low BSFC

### PACKAGE PERFORMANCE

Performance	Standby		Prime	
	50 Hz	60 Hz	50 Hz	60 Hz
Frequency	50 Hz	60 Hz	50 Hz	60 Hz
Genset Power Rating	200.0 kVA	218.8 kVA	180.0 kVA	199.4 kVA
Genset power rating with fan @ 0.8 power factor	160.0 kW	175.0 kW	144.0 kW	159.5 kW
Emissions	Low BSFC			
Performance Number	P4196A	P4198A	P4196A	P4198A
<b>Fuel Consumption</b>				
Fuel Tank Capacity, litres (US gal)	394 (104.1)			
100% load with fan, L/hr (gal/hr)	43.8 (11.6)	50.8 (13.4)	40.2 (10.6)	46.5 (12.3)
75% load with fan, L/hr (gal/hr)	34.2 (9.0)	39.0 (10.3)	30.9 (8.2)	35.5 (9.4)
50% load with fan, L/hr (gal/hr)	22.3 (5.9)	26.1 (6.9)	19.7 (5.2)	23.6 (6.2)
<b>Cooling System¹</b>				
Radiator air flow, m³/min (CFM)	307.2 (10849)	378.0 (13349)	307.2 (10849)	378.0 (13349)
Total coolant capacity, L (gal)	27.0 (7.1)			
<b>Inlet Air</b>				
Max. Combustion Air Intake Restriction, kPa (in water)	3.0 (12.0)			
Combustion air inlet flow rate, m³/min (CFM)	13.9 (490)	16.4 (578)	13.0 (457)	15.5 (546)
Max. Allowable Combustion Air Inlet Temp, °C (°F)	50 (122)			
<b>Exhaust System</b>				
Exhaust stack gas temperature, °C (°F)	538 (1000)	485 (905)	538 (1000)	485 (905)
Exhaust gas flow rate, m³/min (cfm)	33.9 (1195)	38.4 (1354)	31.6 (1114)	35.4 (1251)
Exhaust system backpressure (maximum allowable), kPa (in water)	6.0 (1.8)			
<b>Heat Rejection</b>				
Heat rejection to jacket water, kW (BTU/min)	76.4 (4345)	88.3 (5022)	74.2 (4220)	81.5 (4635)
Heat rejection to alternator, kW (BTU/min)	13.2 (751)	14.0 (796)	13.2 (751)	14.0 (796)
Heat rejection to atmosphere from engine, kW (BTU/min)	25.6 (1456)	33.5 (1905)	22.7 (1291)	29.5 (1678)

Alternator <sup>3</sup>	50 Hz				60 Hz			
	Voltages	415V	400V	380V	220V	480V	440V	380V
Motor starting capability @ 30% Voltage Dip, skVA	328	307	280	364	361	310	237	280
Current, amps	278	289	304	525	263	287	332	607
Temperature Rise, °C	105/40							
Frame Size	M2294L4							
Excitation	S.E							

**WEIGHTS & DIMENSIONS**

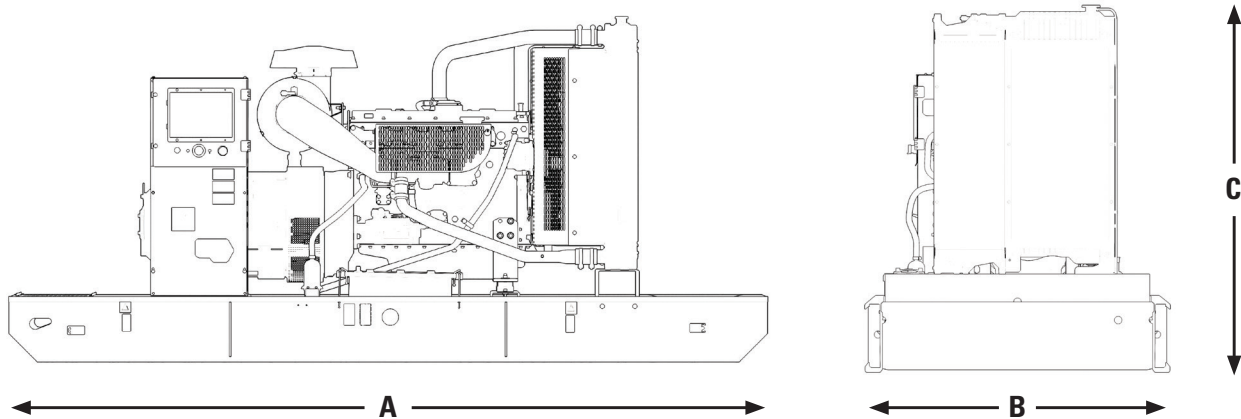

Dim "A" mm (in)	Dim "B" mm (in)	Dim "C" mm (in)	Dry Weight kg (lb)
2510 (98.8)	1010 (39.8)	1640 (64.6)	1532 (3377)

**Note:** General configuration not to be used for installation. See general dimension drawings for detail.

**APPLICABLE CODES AND STANDARDS:**

AS1359, IEC60034-1, ISO 3046, ISO 8528, NEMA MG1-33, EAC, CE, UKCA.

**Note:** Codes may not be available in all model configurations. Please consult your local Cat Dealer representative for availability.

**STANDBY:** Output available with varying load for the duration of the interruption of the normal source power. Average power output is 70% of the standby power rating. Typical operation is 200 hours per year, with maximum expected usage of 500 hours per year.

**PRIME:** Output available with varying load for an unlimited time. Average power output is 70% of the prime power rating. Typical peak demand is 100% of prime rated kW with 10% overload capability for emergency use for a maximum of 1 hour in 12. Overload operation cannot exceed 25 hours per year

**RATINGS:** Ratings are based on SAE J1349 standard conditions. These ratings also apply at ISO 3046 standard conditions.

**DEFINITIONS AND CONDITIONS**

<sup>1</sup> For ambient and altitude capabilities consult your Cat dealer. Air flow restriction (system) is added to existing restriction from factory.

<sup>2</sup> Emissions data measurement procedures are consistent with those described in EPA CFR 40 Part 89, Subpart D & E and ISO 8178-1 for measuring HC, CO, PM, NO<sub>x</sub>. Data shown is based on steady state operating conditions of 77°F, 28.42 in HG and number 2 diesel fuel with 35° API and LHV of 18,390 BTU/lb. The nominal emissions data shown is subject to instrumentation, measurement, facility and engine to engine variations. Emissions data is based on 100% load and thus cannot be used to compare to EPA regulations which use values based on a weighted cycle.

<sup>3</sup> Generator temperature rise is based on a 40° C ambient per IEC60034-1.