

Cat® C7.1

Diesel Generator Sets



Standby & Prime: 50 Hz & 60 Hz



Image shown might not reflect actual configuration.

Engine Model	Cat® C7.1 Inline 4-stroke Diesel
Bore x Stroke	105.0 mm x 135.0 mm (4.1 in x 5.3 in)
Displacement	7.0 L (427.8 in³)
Compression Ratio	16.0:1
Aspiration	Turbocharged Air To Air Charge Cooled
Fuel Injection System	Inline
Governor	Mechanical – G3 Class* capable

Model	Standby		Prime		Emission Strategy
	50 Hz	60 Hz	50 Hz	60 Hz	
DE165E0	165.0 kVA (132.0 kW)	187.5 kVA (150.0 kW)	150.0 kVA (120.0 kW)	168.8 kVA (135.0 kW)	Low BSFC

PACKAGE PERFORMANCE

Performance	Standby		Prime	
	50 Hz	60 Hz	50 Hz	60 Hz
Frequency	50 Hz	60 Hz	50 Hz	60 Hz
Genset Power Rating	165.0 kVA	187.5 kVA	150.0 kVA	168.8 kVA
Genset power rating with fan @ 0.8 power factor	132.0 kW	150.0 kW	120.0 kW	135.0 kW
Emissions	Low BSFC			
Performance Number	P4200A	P4202A	P4200A	P4202A
Fuel Consumption				
Fuel Tank Capacity, litres (US gal)	349 (92.2)			
100% load with fan, L/hr (gal/hr)	35.1 (9.3)	41.1 (10.9)	32.4 (8.6)	37.5 (9.9)
75% load with fan, L/hr (gal/hr)	27.2 (7.2)	31.9 (8.4)	24.9 (6.6)	28.9 (7.6)
50% load with fan, L/hr (gal/hr)	18.3 (4.8)	21.8 (5.8)	16.6 (4.4)	19.7 (5.2)
Cooling System¹				
Radiator air flow, m³/min (CFM)	259.2 (9154)	316.2 (11167)	259.2 (9154)	316.2 (11167)
Total coolant capacity, L (gal)	21.0 (5.5)			
Inlet Air				
Max. Combustion Air Intake Restriction, kPa (in water)	3.0 (12.0)			
Combustion air inlet flow rate, m³/min (CFM)	10.7 (377)	15.0 (529)	10.0 (354)	14.4 (509)
Max. Allowable Combustion Air Inlet Temp, °C (°F)	50 (122)			
Exhaust System				
Exhaust stack gas temperature, °C (°F)	484 (903)	407 (765)	484 (903)	407 (765)
Exhaust gas flow rate, m³/min (CFM)	25.5 (902)	32.2 (1137)	23.9 (843)	31.9 (1125)
Exhaust system backpressure (maximum allowable), kPa (in water)	6.0 (1.8)			
Heat Rejection				
Heat rejection to jacket water, kW (BTU/min)	75.7 (4305)	80.1 (4555)	69.1 (3930)	73.5 (4180)
Heat rejection to alternator, kW (BTU/min)	10.2 (580)	11.1 (631)	10.2 (580)	11.1 (631)
Heat rejection to atmosphere from engine, kW (BTU/min)	22.4 (1274)	23.4 (1331)	19.9 (1132)	20.8 (1183)

Alternator ²	50 Hz				60 Hz			
	Voltages	415V	400V	380V	220V	480V	440V	380V
Motor starting capability @ 30% Voltage Dip, skVA	233	219	199	259	257	220	169	199
Current, amps	230	238	251	390	226	246	267	520
Temperature Rise, °C	125/40							
Frame Size	M2256L4							
Excitation	S.E							

WEIGHTS & DIMENSIONS

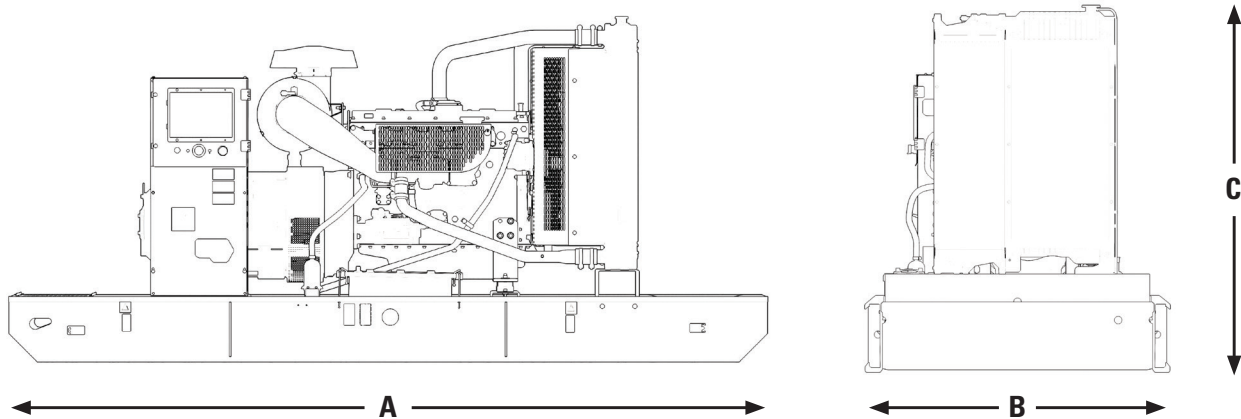

Dim "A" mm (in)	Dim "B" mm (in)	Dim "C" mm (in)	Dry Weight kg (lb)
2500 (98.4)	1120 (44.1)	1528 (60.2)	1575 (3472)

Note: General configuration not to be used for installation. See general dimension drawings for detail.

APPLICABLE CODES AND STANDARDS:

AS1359, IEC60034-1, ISO 3046, ISO 8528, NEMA MG1-33, EAC,CE,UKCA.

Note: Codes may not be available in all model configurations. Please consult your local Cat Dealer representative for availability.

STANDBY: Output available with varying load for the duration of the interruption of the normal source power. Average power output is 70% of the standby power rating. Typical operation is 200 hours per year, with maximum expected usage of 500 hours per year.

PRIME: Output available with varying load for an unlimited time. Average power output is 70% of the prime power rating. Typical peak demand is 100% of prime rated kW with 10% overload capability for emergency use for a maximum of 1 hour in 12. Overload operation cannot exceed 25 hours per year

RATINGS: Ratings are based on SAE J1349 standard conditions. These ratings also apply at ISO 3046 standard conditions.

DEFINITIONS AND CONDITIONS

¹ For ambient and altitude capabilities consult your Cat dealer. Air flow restriction (system) is added to existing restriction from factory.

² Generator temperature rise is based on a 40° C ambient per IEC60034-1.

*Governing Class capability as per ISO 8528-5 for 60 Hz application only.Consult your local Cat dealer for configuration and site specific transient performance classification.