

Cat® D25

Diesel Generator Sets



Standby : 60 Hz



Image shown may not reflect actual configuration

Engine Model	Cat® C2.2 In-line 4, 4-cycle diesel
Bore x Stroke	84 mm x 100 mm (3.3 in x 3.93 in)
Displacement	2.2 L (134 in ³)
Compression Ratio	23.3:1
Aspiration	Turbocharged
Fuel Injection System	Mechanical Cassette type

Model	Standby 60 Hz ekW	Emission Strategy
D25	25	EPA TIER 4I (EPA 40 CFR Part 1039 Interim Tier 4)

Package Performance

Performance	Standby	
	3-Phase	1-Phase
Frequency	60	60
Genset Power Rating, kVA	31.3	31.3
Genset power rating with fan, kW, 3p@ 0.8 & 1p@1.0 power factor	25	25
Performance Number	P3528A	P3528A
Fuel Consumption		
100% load with fan, L/hr (gal/hr)	9.3(2.45)	9.3(2.45)
75% load with fan, L/hr (gal/hr)	6.6(1.74)	6.6(1.74)
50% load with fan, L/hr (gal/hr)	5.1 (1.35)	5.1 (1.35)
Cooling System¹		
Radiator air flow, m ³ /min (cfm)	112 (3955)	
Radiator air flow restriction (system), kPa (in. water)	0.12	
Engine coolant capacity, L (gal)	3.6 (0.95)	
Radiator coolant capacity, L (gal)	5.72 (1.51)	
Total coolant capacity, L (gal)	9.32 (2.46)	
Inlet Air		
Max. Combustion Air Intake Restriction kPa (in. water)	6.4 (25.7)	6.4 (25.7)
Combustion air inlet flow rate, m ³ /min (cfm)	2.49 (87.9)	2.49 (87.9)
Exhaust System		
Exhaust stack gas temperature, °C (°F)	530 (986)	530 (986)
Exhaust gas flow rate, m ³ /min (cfm)	7.5 (265)	7.5 (265)
Exhaust system backpressure (maximum allowable) kPa (in. water)	10.2 (41.0)	10.2 (41.0)
Heat Rejection		
Heat rejection to jacket water, kW (Btu/min)	33.7 (1916)	33.7 (1916)
Heat rejection from Alternator, kW (Btu/min)	4.2 (238)	4.6 (262)
Heat rejection to atmosphere from engine, kW (Btu/min)	7.2 (409)	7.2 (409)
Heat rejection to exhaust (total) kW (Btu/min)	25.6 (1456)	25.6 (1456)

D25 Diesel Generator Sets

Electric Power



Alternator ³	60 Hz				
	Voltages	480/277	240/120	208/120	600/346
Motor starting capability @ 30% Voltage Dip, skVA	42	33	32	43	53
Current Amps	45	90	104	36	125
Frame Size	M1717L4				M1736L4
Excitation	S.E				
Temperature Rise, °C	125/40	125/40	125/40	125/40	105/40

Weights and Dimensions

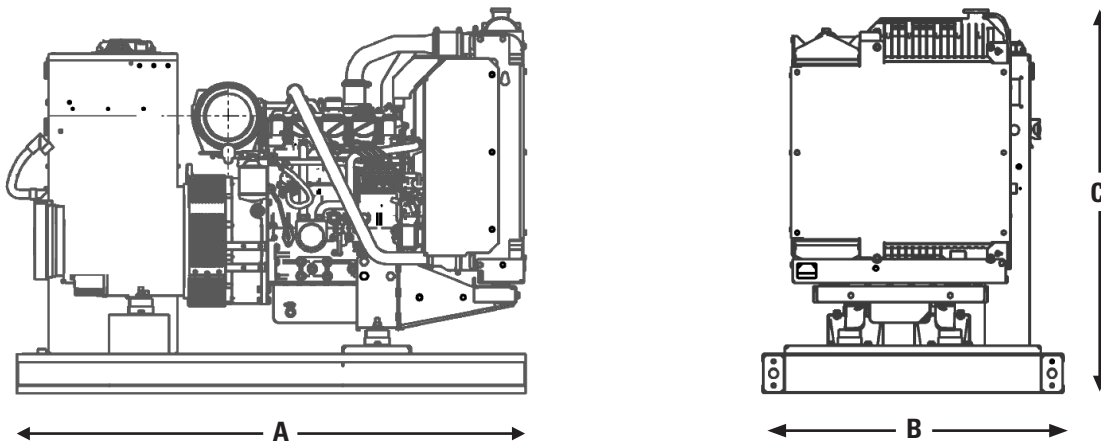

Dim "A" mm (in)	Dim "B" mm (in)	Dim "C" mm (in)	Dry Weight kg (lb)
1503 (59)	970 (38)	1169 (46)	498 (1098)

Note: General configuration not to be used for installation. See general dimension drawings for detail.

APPLICABLE CODES AND STANDARDS:

AS1359, CSA C22.2 No100-04, UL142, UL489, UL869, UL2200, NFPA37, NFPA70, NFPA99, NFPA110, IBC, IEC60034-1, ISO3046, ISO8528, NEMA MG1-22, NEMA MG1-33, 2006/95/EC, 2006/42/EC, 2004/108/EC.

Note: Codes may not be available in all model configurations. Please consult your local Cat Dealer representative for availability.

STANDBY: Output available with varying load for the duration of the interruption of the normal source power. Average power output is 70% of the standby power rating. Typical operation is 200 hours per year, with maximum expected usage of 500 hours per year.

RATINGS: Ratings are based on SAE J1349 standard conditions. These ratings also apply at ISO3046 standard conditions.

LET'S DO THE WORK.™

LEHE20838-01 (12/22)

www.cat.com/electricpower
©2022 Caterpillar. All rights reserved.

Materials and specifications are subject to change without notice. The International System of Units (SI) is used in this publication. CAT, CATERPILLAR, LET'S DO THE WORK, their respective logos, "Caterpillar Corporate Yellow", the "Power Edge" and Cat "Modern Hex" trade dress as well as corporate and product identity used herein, are trademarks of Caterpillar and may not be used without permission.