

# Cat® DG45

## GAS GENERATOR SETS

### NORTH AMERICA

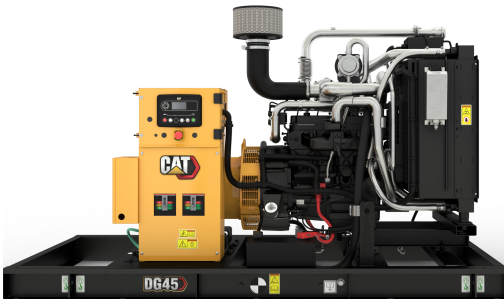

Image shown may not reflect actual configuration

Engine Model	3.6L TCAC Inline
No. of Cylinders	4
Bore x Stroke	105.54 mm x 102.9 mm
Displacement	3.6 Liter
Compression Ratio	9.7:1
Aspiration	Turbocharged & Aftercooled
Fuel / Ignition System	Electronic Regulator / Spark Ignition
Governor	Electronic - G2 Class* capable

### For North America, 60 Hz Market

Model	Emergency Standby		Emissions Strategy
	Natural Gas ekW	Propane ekW	
DG45	45	45	U.S. EPA Certified for Stationary Emergency Application

### PACKAGE PERFORMANCE

Performance	Emergency Standby	
	Natural Gas	Propane
Frequency	60 Hz	
Genset power rating, ekW (3-Phase / 1-Phase)	45 / 45	45 / 45
Performance Numbers (3-Phase / 1-Phase)	EM7255 / EM7259	EM7257 / EM7261
<b>Fuel System / Fuel Consumption</b>		
Minimum required fuel delivery pressure at rail connector, psi (in. water)	0.32 (9)	
Maximum required fuel delivery pressure at rail connector, psi (in. water)	0.43 (12)	
100% load with fan, kg/hr (CFH)	13.3 (602)	14.3 (267)
75% load with fan, kg/hr (CFH)	10.8 (466)	11.3 (211)
50% load with fan, kg/hr (CFH)	7.6 (328)	8.1 (151)
<b>Cooling System<sup>1</sup></b>		
Radiator air flow, m <sup>3</sup> /min (CFM)	162 (5721)	
Radiator air flow restriction (system), kPa (in. water)	0.12	
Engine coolant capacity, L (gal)	2.5 (0.625)	
Radiator coolant capacity, L (gal)	4.7 (1.25)	
Total coolant capacity, L (gal)	15.1 (4)	
<b>Inlet Air</b>		
Combustion air inlet flow rate, m <sup>3</sup> /min (CFM) (kg/hr)	3.35 (118) (222.6)	3.18 (112) (211.9)
Maximum allowable intake air restriction, kPa (in. water)	3.49 (14)	
<b>Exhaust System</b>		
Exhaust gas temperature after turbo, °C (°F)	730 (1346)	741 (1366)
Exhaust gas flow rate, m <sup>3</sup> /min (CFM) (kg/hr)	12.3 (434) (236)	12.4 (438) (239)
Maximum allowable exhaust system back pressure, kPa (in. water)	7 (28)	
<b>Heat Rejection</b>		
Heat rejection to jacket water, kW (BTU/min)	37.2 (2115)	37.2 (2115)
Heat rejection to after cooler, kW (BTU/min)	4.8 (273)	3.3 (188)
Heat rejection to oil cooler, kW (BTU/min)	6.8 (387)	6.7 (381)
Heat rejection to atmosphere from engine, kW (BTU/min)	11.8 (671)	23.6 (1342)
Heat rejection to exhaust, kW (BTU/min)	60 (3412)	57 (3241)

<b>Lube System</b>	
Sump refill with filter, L (gal)	8.3 (2.2)
Maximum oil temperature, °C (°F)	122 (250)
Maximum oil capacity, L (gal) (with cooling package)	12.1 (3.19)
Minimum oil capacity, L (gal) (with cooling package)	9.7 (2.6)
<b>Emissions (Meets EPA Stationary Emergency Limits)</b>	
NOx + HC, g/kW-hr	13.4
CO, g/kW-hr	519

**ALTERNATOR DATA**

<b>DG45</b>						
Alternator	60 Hz 3-Phase					60 Hz 1-Phase
Voltages	480/277	240/120	240/139	208/120	600/346	240/120
Motor starting capability @ 30% Voltage Dip, skVA	127	102	102	119	149	114
Current, Amps - Natural Gas / Propane	68/68	136/136	136/136	156/156	54/54	188/188
Temperature rise <sup>2</sup> , °C	105	105	105	105	105	105
Frame size	M1775L4	M1775L4	M1775L4	M1775L4	M1775L4	M1775L4
Excitation	PMG	PMG	PMG	PMG	PMG	SE

Motor starting capability is based on the assumption of 0.6 pf.

Temperature rise is based on the rating type and the respective site conditions.

**WEIGHTS & DIMENSIONS**

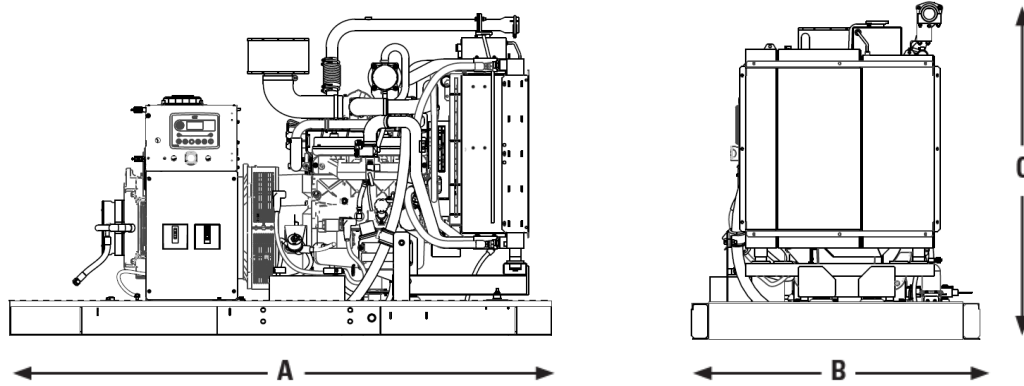

Length "A" mm (in)	Width "B" mm (in)	Height "C" mm (in)	Dry Weight Kg (lb)
2365 (93)	1193 (47)	1400 (55)	901 (1986)

**Note:** General configuration not to be used for installation. See general dimension drawings for detail.

**APPLICABLE CODES AND STANDARDS:**

CSA C22.2 No 100-04, UL142, UL489, UL869, cUL/UL2200, NFPA 37, NFPA 70, NFPA 99, NFPA 110, IBC, IEC60034-1, ISO 3046, ISO 8528, NEMA MG 1-33.

**EMERGENCY STANDBY POWER (ESP):** Output available with varying load for the duration of the interruption of the normal source power. Average power output is 70% of the standby rated kW. Typical operation is 50 hours per year, with maximum expected usage of 200 hours per year.

**Ratings** are based on SAE J1349 standard conditions. These ratings also apply at ISO 3046 standard conditions.

**1 CFH = 1000 BTU/HR**

Fuel Rates are based on LHV of 35.83 MJ/Nm<sup>3</sup> for Natural Gas and 92.1 MJ/Nm<sup>3</sup> for Propane Vapor @77°F (25°C) and 328 ft (100 m) above sea level and a relative humidity of 30%. Temperatures and elevations greater than this standard must be accounted for as follows:

- A derate of 1.5% for every 5°C above 25°C air inlet temperature.
- A derate of 2.2% for every 200m above 100m.

**DEFINITIONS AND CONDITIONS**

- <sup>1</sup> For ambient and altitude capabilities, consult your Cat dealer. Air flow restriction (system) is added to the existing restriction from the factory.
- <sup>2</sup> Generator temperature rise is based on 40°C (104°F) ambient per NEMA MG1-32.
- \*Governing Class capability as per ISO-8528-5. Consult your local Cat dealer for configuration and site specific transient performance classification.

**LET'S DO THE WORK.™**

# Cat® DG45

## GAS GENERATOR SETS

### LATIN AMERICA



Image shown may not reflect actual configuration

Engine Model	3.6L TCAC Inline
No. of Cylinders	4
Bore x Stroke	105.54 mm x 102.9 mm
Displacement	3.6 Liter
Compression Ratio	9.7:1
Aspiration	Turbocharged & Aftercooled
Fuel / Ignition System	Electronic Regulator / Spark Ignition
Governor	Electronic - G2 Class* capable

### For Latin America, 60 Hz Market

Model	Emergency Standby		Emissions Strategy
	Natural Gas ekW	Propane ekW	
DG45	45	45	U.S. EPA Certified for Stationary Emergency Application

### PACKAGE PERFORMANCE

Performance	Emergency Standby	
	Natural Gas	Propane
Frequency	60 Hz	
Genset power rating, ekW (3-Phase / 1-Phase)	45 / 45	45 / 45
Performance Numbers (3-Phase / 1-Phase)	EM7255 / EM7259	EM7257 / EM7261
<b>Fuel System / Fuel Consumption</b>		
Minimum required fuel delivery pressure at rail connector, psi (in. water)	0.32 (9)	
Maximum required fuel delivery pressure at rail connector, psi (in. water)	0.43 (12)	
100% load with fan, kg/hr (CFH)	13.3 (602)	14.3 (267)
75% load with fan, kg/hr (CFH)	10.8 (466)	11.3 (211)
50% load with fan, kg/hr (CFH)	7.6 (328)	8.1 (151)
<b>Cooling System<sup>1</sup></b>		
Radiator air flow, m <sup>3</sup> /min (CFM)	162 (5721)	
Radiator air flow restriction (system), kPa (in. water)	0.12	
Engine coolant capacity, L (gal)	2.5 (0.625)	
Radiator coolant capacity, L (gal)	4.7 (1.25)	
Total coolant capacity, L (gal)	15.1 (4)	
<b>Inlet Air</b>		
Combustion air inlet flow rate, m <sup>3</sup> /min (CFM) (kg/hr)	3.35 (118) (222.6)	3.18 (112) (211.9)
Maximum allowable intake air restriction, kPa (in. water)	3.49 (14)	
<b>Exhaust System</b>		
Exhaust gas temperature after turbo, °C (°F)	730 (1346)	741 (1366)
Exhaust gas flow rate, m <sup>3</sup> /min (CFM) (kg/hr)	12.3 (434) (236)	12.4 (438) (239)
Maximum allowable exhaust system back pressure, kPa (in. water)	7 (28)	
<b>Heat Rejection</b>		
Heat rejection to jacket water, kW (BTU/min)	37.2 (2115)	37.2 (2115)
Heat rejection to after cooler, kW (BTU/min)	4.8 (273)	3.3 (188)
Heat rejection to oil cooler, kW (BTU/min)	6.8 (387)	6.7 (381)
Heat rejection to atmosphere from engine, kW (BTU/min)	11.8 (671)	23.6 (1342)
Heat rejection to exhaust, kW (BTU/min)	60 (3412)	57 (3241)

<b>Lube System</b>	
Sump refill with filter, L (gal)	8.3 (2.2)
Maximum oil temperature, °C (°F)	122 (250)
Maximum oil capacity, L (gal) (with cooling package)	12.1 (3.19)
Minimum oil capacity, L (gal) (with cooling package)	9.7 (2.6)
<b>Emissions (Meets EPA Stationary Emergency Limits)</b>	
NOx + HC, g/kW-hr	13.4
CO, g/kW-hr	519

**ALTERNATOR DATA**

<b>DG45</b>								
Alternator	60 Hz 3-Phase							60 Hz 1-Phase
	Voltages	480/277	380/220	240/120	240/139	220/127	208/120	600/346
Motor starting capability @ 30% Voltage Dip, skVA	127	88	102	102	99	119	149	114
Current, Amps - Natural Gas / Propane	68/68	85.5/85.5	136/136	136/136	148/148	156/156	54/54	188/188
Temperature rise <sup>2</sup> , °C	105	105	105	105	105	105	105	105
Frame size	M1775L4	M1775L4	M1775L4	M1775L4	M1775L4	M1775L4	M1775L4	M1775L4
Excitation	PMG	PMG	PMG	PMG	PMG	PMG	PMG	SE

Motor starting capability is based on the assumption of 0.6 pf.

Temperature rise is based on the rating type and the respective site conditions.

**WEIGHTS & DIMENSIONS**

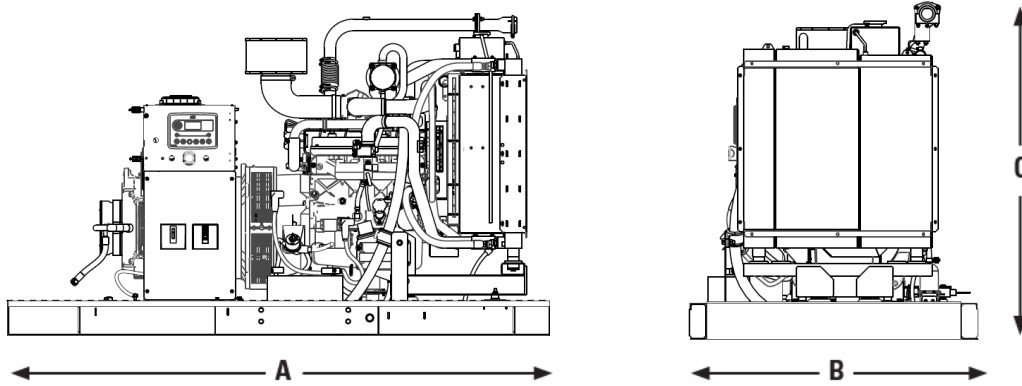

Length "A" mm (in)	Width "B" mm (in)	Height "C" mm (in)	Dry Weight Kg (lb)
2365 (93)	1193 (47)	1400 (55)	901 (1986)

**Note:** General configuration not to be used for installation. See general dimension drawings for detail.

**APPLICABLE CODES AND STANDARDS:**

CSA C22.2 No 100-04, UL142, UL489, UL869, cUL/UL2200, NFPA 37, NFPA 70, NFPA 99, NFPA 110, IBC, IEC60034-1, ISO 3046, ISO 8528, NEMA MG 1-33.

Note: Codes may not be available in all model configurations. Please consult your local Cat dealer for availability.

**EMERGENCY STANDBY POWER (ESP):** Output available with varying load for the duration of the interruption of the normal source power. Average power output is 70% of the standby rated kW. Typical operation is 50 hours per year, with maximum expected usage of 200 hours per year.

**Ratings** are based on SAE J1349 standard conditions. These ratings also apply to ISO 3046 standard conditions.

**1 CFH = 1000 BTU/HR**

Fuel Rates are based on LHV of 35.83 MJ/Nm<sup>3</sup> for Natural Gas and 92.1 MJ/Nm<sup>3</sup> for Propane Vapor @77°F (25°C) and 328 ft (100 m) above sea level and a relative humidity of 30%. Temperatures and elevations greater than this standard must be accounted for as follows:

A derate of 1.5% for every 5°C above 25°C air inlet temperature.  
 A derate of 2.2% for every 200m above 100m.

**DEFINITIONS AND CONDITIONS**

- <sup>1</sup> For ambient and altitude capabilities, consult your Cat dealer. Air flow restriction (system) is added to the existing restriction from the factory.
- <sup>2</sup> Generator temperature rise is based on 40°C (104°F) ambient per NEMA MG1-32.
- \*Governing Class capability as per ISO-8528-5. Consult your local Cat dealer for configuration and site specific transient performance classification.

**LET'S DO THE WORK.™**