

Cat® D200 GC

Diesel Generator Sets



Standby : 60 Hz



Image shown might not reflect actual configuration

Engine Model	Cat® C7.1 In-line 6, 4-cycle Diesel
Bore x Stroke	105 mm x 135 mm (4.1 in x 5.3 in)
Displacement	7.01 L (428 in ³)
Compression Ratio	16.7:1
Aspiration	Turbocharged Air-to-Air-Aftercooled
Fuel Injection System	Electronic, Common Rail
Governor	Electronic ADEM™ A4

Model	Standby	Emission Strategy
D200 GC	250 kVA, 200 ekW	EPA TIER III

PACKAGE PERFORMANCE

Performance	Standby
Frequency	60 Hz
Genset Power Rating	250 kVA
Genset power rating with fan, 3p@ 0.8 power factor	200 ekW
Performance Number	P4364A
Fuel Consumption	
100% load with fan, L/hr (gal/hr)	56.4 (14.9)
75% load with fan, L/hr (gal/hr)	45.8 (12.1)
50% load with fan, L/hr (gal/hr)	32.6 (8.6)
25% load with fan, L/hr (gal/hr)	14.3 (3.7)
Cooling System ¹	
Radiator air flow restriction (system), kPa (in. water)	0.12 (0.48)
Engine coolant capacity, L (gal)	9.5 (2.5)
Radiator coolant capacity, L (gal)	11.5 (3.0)
Inlet Air	
Combustion air inlet flow rate, m ³ /min (CFM)	15.8 (558)
Max. allowable combustion air inlet temp, °C (°F)	51 (124)
Exhaust System	
Exhaust stack gas temperature, °C (°F)	533 (991)
Exhaust gas flow rate, m ³ /min (CFM)	38.3 (1353)
Exhaust system back pressure (maximum allowable), kPa (in. water)	15.0 (60.2)
Heat Rejection	
Heat rejection to jacket water, kW (BTU/min)	91.8 (5221)
Heat rejection to exhaust (total), kW (BTU/min)	183.0 (10407)
Heat rejection to aftercooler, kW (BTU/min)	45.0 (2559)
Heat rejection to atmosphere from engine, kW (BTU/min)	35.3 (2019)

D200 GC Diesel Generator Sets

Electric Power



Emissions (Nominal) ²	Standby		
NOx + HC, g/kW-hr	3.73		
CO, g/kW-hr	1.31		
PM, g/kW-hr	0.18		
Alternator ³			
Voltages	480V	208V	600V
Motor starting capability @ 30% Voltage Dip, skVA	361	333	780
Current, Amps	301	694	241
Frame Size	M2294L4	M2736L4	M2736L4
Excitation	SE	SE	AREP
Temperature Rise, °C	130	130	105

WEIGHTS & DIMENSIONS

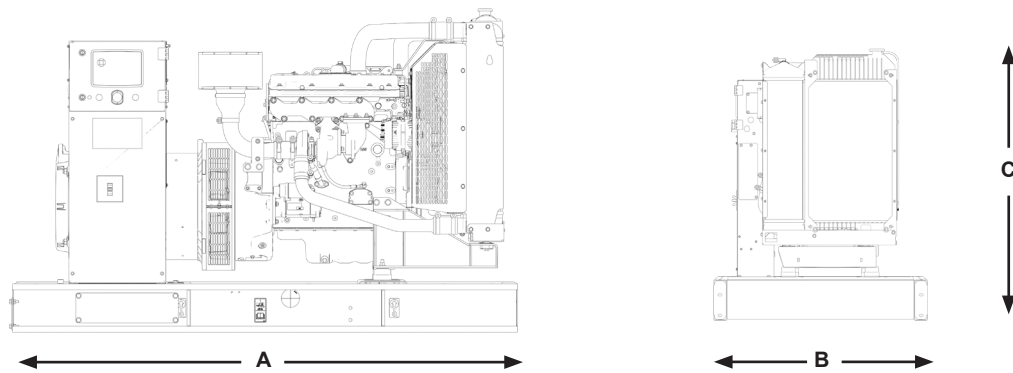

Note: General configuration not to be used for installation. See general dimension drawings for detail.

Dim "A" mm (in)	Dim "B" mm (in)	Dim "C" mm (in)	Dry Weight kg (lb)
2634 (103.7)	1300 (51.2)	1492 (58.7)	1777 (3917)

APPLICABLE CODES AND STANDARDS:

CSA C22.2 No 100-04, UL142, UL489, UL869, cUL/UL2200, NFPA 37, NFPA 70, NFPA 99, NFPA 110, IBC, IEC60034-1, ISO 3046, ISO 8528, NEMA MG 1-33.

Note: Codes may not be available in all model configurations. Please consult your local Cat Dealer representative for availability.

STANDBY: Output available with varying load for the duration of the interruption of the normal source power. Average power output is 70% of the standby power rating. Typical operation is 200 hours per year, with maximum expected usage of 500 hours per year.

RATINGS: Ratings are based on SAE J1349 standard conditions. These ratings also apply at ISO3046 standard conditions.

DEFINITIONS AND CONDITIONS

¹ For ambient and altitude capabilities consult your Cat dealer. Air flow restriction (system) is added to existing restriction from factory.

² Emissions data measurement procedures are consistent with those described in EPA CFR 40 Part 89, Subpart D & E and ISO8178-1 for measuring HC, CO, PM, NOx. Data shown is based on steady state operating conditions of 77° F, 28.42 in HG and number 2 diesel fuel with 35° API and LHV of 18,390 BTU/lb. The nominal emissions data shown is subject to instrumentation, measurement, facility and engine to engine variations. Emissions data is based on 100% load and thus cannot be used to compare to EPA regulations which use values based on a weighted cycle.

³ UL 2200 Listed packages may have oversized generators with a different temperature rise and motor starting characteristics. Generator temperature rise is based on a 40° C ambient per NEMA MG1-32.

LET'S DO THE WORK.™

LEHE2668-01 (01/21)

Materials and specifications are subject to change without notice. The International System of Units (SI) is used in this publication. CAT, CATERPILLAR, LET'S DO THE WORK, their respective logos, "Caterpillar Corporate Yellow", the "Power Edge" and Cat "Modern Hex" trade dress as well as corporate and product identity used herein, are trademarks of Caterpillar and may not be used without permission.

www.cat.com/electricpower
 © 2021 Caterpillar. All Rights Reserved.