

Shown with
Optional Equipment

CAT® ENGINE SPECIFICATIONS

In-line 4, 4-Stroke-Cycle

Bore	121 mm (4.8 in.)
Stroke	152 mm (6.0 in.)
Displacement	7.0 L (425 cu. in.)
Aspiration	Naturally Aspirated
Governor and Protection	Hydra-mechanical
Combustion	Rich Burn
Engine Weight, net dry (approx)	757.5 kg (1670 lb)
Power Density	10.7 kg/kW (17.6 lb/bhp)
Power per Displacement	13.6 bhp/L
Jacket Water Capacity	16.0 L (4.2 gal)
Lube Oil System (refill)	31.2 L (8.3 gal)
Oil Change Interval	750 hours
Rotation (from flywheel end)	Counterclockwise
Flywheel and Flywheel Housing	SAE No. 1
Flywheel Teeth	156

FEATURES

Engine Design

- Proven reliability and durability
- Ability to burn a wide spectrum of gaseous fuels
- Robust diesel strength design prolongs life and lowers owning and operating costs
- Broad operating speed range

Full Range of Attachments

Large variety of factory-installed engine attachments reduces packaging time

Testing

Every engine is full-load tested to ensure proper engine performance.

Gas Engine Rating Pro

GERP is a PC-based program designed to provide site performance capabilities for Cat® natural gas engines for the gas compression industry. GERP provides engine data for your site's altitude, ambient temperature, fuel, engine coolant heat rejection, performance data, installation drawings, spec sheets, and pump curves.

Product Support Offered Through Global Cat Dealer Network

More than 2,200 dealer outlets

Cat factory-trained dealer technicians service every aspect of your petroleum engine

Cat parts and labor warranty

Preventive maintenance agreements available for repair-before-failure options

S•O•SSM program matches your oil and coolant samples against Caterpillar set standards to determine:

- Internal engine component condition
- Presence of unwanted fluids
- Presence of combustion by-products
- Site-specific oil change interval

Over 80 Years of Engine Manufacturing Experience

Over 60 years of natural gas engine production

Ownership of these manufacturing processes enables Caterpillar to produce high quality, dependable products.

- Cast engine blocks, heads, cylinder liners, and flywheel housings
- Machine critical components
- Assemble complete engine

Web Site

For all your petroleum power requirements, visit www.catoilandgas.cat.com.

STANDARD EQUIPMENT

Air Inlet System

Air cleaner
Air cleaner rain cap
Service indicator

Control System

Hydra-mechanical governor

Cooling System

Thermostats and housing
Jacket water pump — gear-driven

Exhaust System

Watercooled exhaust manifolds
Dry exhaust elbow

Flywheel & Flywheel Housing

SAE No. 1 flywheel
SAE No. 1 flywheel housing
SAE standard rotation

Fuel System

Gas pressure regulator
Natural gas carburetor

Ignition System

Altronic V ignition system

Instrumentation

Service meter

Lube System

Crankcase breather — top mounted
Oil cooler
Oil pan — full sump
Oil filler and dipstick

Mounting System

Engine supports

Protection System

Shutoffs

General

Paint — Cat yellow
Crankshaft drive pulley
Lifting eyes

OPTIONAL EQUIPMENT

Charging System

Battery chargers
Charging alternators
Ammeter gauge
Ammeter gauge and wiring

Control System

Vernier and positive locking control

Cooling System

Expansion tank
Heat exchanger/expansion tank
Radiator
Blower fan
Suction fan
Belt tightener
Fan drive

Exhaust System

Flexible fittings
Elbows
Flange
Pipe
Rain cap
Mufflers

Ignition System

Altronic III
CSA shielded ignition
Wiring harness

Instrumentation

Gauges and instrument panels

Lube System

Lubricating oil

Mounting System

Vibration isolators

Power Take-Offs

Auxiliary drive pulleys
Auxiliary pump
Enclosed clutch
Flywheel stub shaft
Front stub shaft

Protection System

Mechanical shutoffs
Gas valves

Starting System

Air starting motor
Air pressure regulator
Air silencer
Electric starting motor
Battery sets
Battery cables
Battery rack

General

Tool set

TECHNICAL DATA
G3304 Gas Petroleum Engine — 1800 rpm

		TM9744-06
Engine Power		
@ 100% Load	bkW (bhp)	71 (95)
@ 75% Load	bkW (bhp)	53 (71)
Engine Speed		
Max Altitude @ Rated Torque and 38°C (100°F)	rpm	1800
Speed Turndown @ Max Altitude, Rated Torque, and 38°C (100°F)	m (ft)	0
	%	48.3
AC Temperature		
	°C (°F)	—
Emissions*		
NOx	g/bkW-hr (g/bhp-hr)	28.3 (21.08)
CO	g/bkW-hr (g/bhp-hr)	2.15 (1.6)
CO ₂	g/bkW-hr (g/bhp-hr)	667 (498)
VOC**	g/bkW-hr (g/bhp-hr)	0.32 (0.24)
Fuel Consumption***		
@ 100% Load	MJ/bkW-hr (Btu/bhp-hr)	10.71 (7567)
@ 75% Load	MJ/bkW-hr (Btu/bhp-hr)	11.10 (7842)
Heat Balance		
Heat Rejection to Jacket Water		
@ 100% Load	bkW (Btu/min)	66.8 (3800)
@ 75% Load	bkW (Btu/min)	54.1 (3076)
Heat Rejection to Aftercooler		
@ 100% Load	bkW (Btu/min)	—
@ 75% Load	bkW (Btu/min)	—
Heat Rejection to Exhaust (LHV to 77°F)		
@ 100% Load	bkW (Btu/min)	55.6 (3163)
@ 75% Load	bkW (Btu/min)	42.6 (2425)
Exhaust System		
Exhaust Gas Flow Rate		
@ 100% Load	m ³ /min (cfm)	13 (459)
@ 75% Load	m ³ /min (cfm)	10.17 (359)
Exhaust Stack Temperature		
@ 100% Load	°C (°F)	548 (1018)
@ 75% Load	°C (°F)	529 (984)
Intake System		
Air Inlet Flow Rate		
@ 100% Load	m ³ /min (scfm)	4.25 (150)
@ 75% Load	m ³ /min (scfm)	3.40 (120)
Gas Pressure		
	kPag (psig)	10.34-34.47 (1.5-5)

*at 100% load and speed, all values are listed as not to exceed

**Volatile organic compounds as defined in U.S. EPA 40 CFR 60, subpart JJJJ

***ISO 3046/1

DIMENSIONS

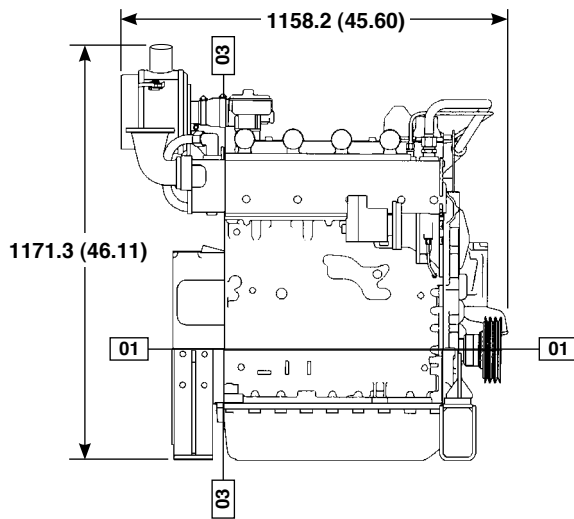

RIGHT SIDE VIEW

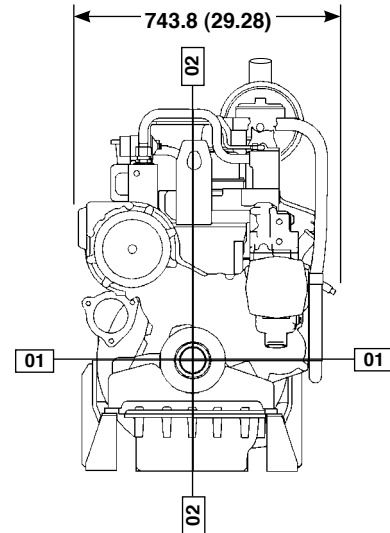

FRONT VIEW

PACKAGE DIMENSIONS		
Length	mm (in.)	1158.2 (45.60)
Width	mm (in.)	743.8 (29.28)
Height	mm (in.)	1171.3 (46.11)
Shipping Weight	kg (lb)	757.5 (1670)

Note: General configuration not to be used for installation. See general dimension drawing 5N-6644 for detail.

Dimensions are in mm (inches).

RATING DEFINITIONS AND CONDITIONS

Engine performance is obtained in accordance with SAE J1995, ISO3046/1, BS5514/1, and DIN6271/1 standards.

Transient response data is acquired from an engine/generator combination at normal operating temperature and in accordance with ISO3046/1 standard ambient conditions. Also in accordance with SAE J1995, BS5514/1, and DIN6271/1 standard reference conditions.

Conditions: Power for gas engines is based on fuel having an LHV of 33.74 kJ/L (905 Btu/cu ft) at 101 kPa (29.91 in. Hg) and 15° C (59° F). Fuel rate is based on a cubic meter at 100 kPa (29.61 in. Hg) and 15.6° C (60.1° F). Air flow is based on a cubic foot at 100 kPa (29.61 in. Hg) and 25° C (77° F). Exhaust flow is based on a cubic foot at 100 kPa (29.61 in. Hg) and stack temperature.

Materials and specifications are subject to change without notice. The International System of Units (SI) is used in this publication.

CAT, CATERPILLAR, their respective logos, S•O•S, "Caterpillar Yellow" and the "Power Edge" trade dress, as well as corporate and product identity used herein, are trademarks of Caterpillar and may not be used without permission.