

Cat® DE715 GC

Diesel Generator Sets



Standby: 50 Hz



Image shown may not reflect actual configuration

Engine Model	Cat® C15 In-line 6, 4-cycle diesel
Bore x Stroke	137 mm x 171 mm (5.4 in x 6.8 in)
Displacement	15.2 L (928 in³)
Compression Ratio	16.1:1
Aspiration	Turbocharged Air-to-Air Aftercooled
Fuel Injection System	EUI
Governor	Electronic ADEM™ A4 - G3 Class* capable

Model	Standby 50 Hz kVA (ekW)	Emission Strategy
DE715 GC	715.0 (572.0)	Low BSFC

PACKAGE PERFORMANCE

Performance	Standby 50 Hz
Genset power rating	715.0
Genset power rating with fan @ 0.8 power factor	572.0
Emissions	Low BSFC
Performance number	EM5626
Fuel Consumption	
Fuel tank capacity, Litres (US gal)	910 (240.4)
100% load with fan, L/hr (gal/hr)	142.2 (37.6)
75% load with fan, L/hr (gal/hr)	106.7 (28.2)
50% load with fan, L/hr (gal/hr)	73.4 (19.4)
Cooling System ¹	
Radiator air flow, m³/min (cfm)	477 (16845)
Radiator air flow restriction (system), kPa (in. water)	0.125 (0.5)
Total coolant capacity, L (gal)	48 (12.7)
Inlet Air	
Max. combustion air intake restriction, kPa (in. water)	6.22 (25)
Combustion air inlet flow rate, m³/min (kg/hr)	36.82 (2598)
Exhaust System	
Exhaust stack gas temperature, °C (°F)	563.1 (1046)
Exhaust gas flow rate, m³/min (cfm)	109.3 (3860)
Exhaust system backpressure (minimum allowable), kPa (in. water)	9 (36)
Exhaust system backpressure (maximum allowable), kPa (in. water)	16.67 (67)
Heat Rejection	
Heat rejection to jacket water, kW (Btu/min)	194 (11033)
Heat rejection to exhaust (total), kW (Btu/min)	536 (30482)
Heat rejection to atmosphere from engine, kW (Btu/min)	43.5 (2474)
Heat rejection to aftercooler, kW (Btu/min)	136 (7734)

DE715 GC Diesel Generator Sets

Electric Power



Alternator ²	50 Hz		
	Voltages	380V	415V
Motor starting capability @ 30% Voltage Dip, skVA	1661	2217	1844
Current, amps	994.7	1032.0	1086.3
Temperature Rise, °C	150		
Frame Size	A3355L41		
Excitation	S.E		

WEIGHTS & DIMENSIONS

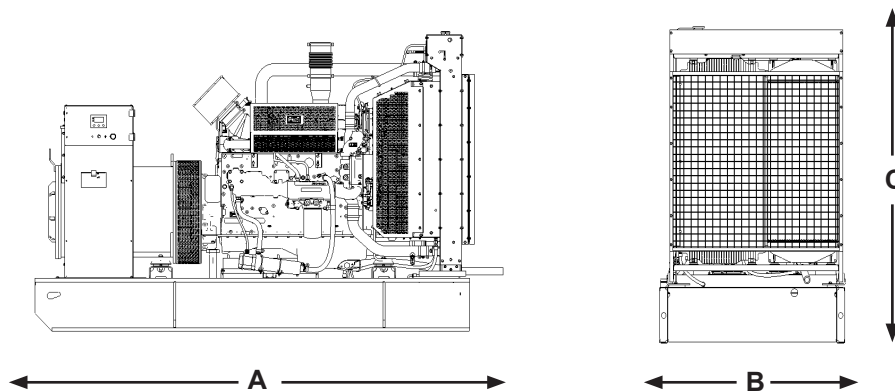

Length "A" mm (in)	Width "B" mm (in)	Height "C" mm (in)	Dry Weight kg (lb)
3328 (131.0)	1540 (60.6)	2187 (86.1)	3907 (8613.4)

Note: General configuration not to be used for installation. See general dimension drawings for detail.

APPLICABLE CODES AND STANDARDS:

AS1359, NFPA37, NFPA70, NFPA99, NFPA110, IEC 60034-1, ISO 3046, ISO 8528, 2006/95/EC, 2006/42/EC, 2004/108/EC.
Note: Codes may not be available in all model configurations. Please consult your local Cat Dealer representative for availability.

STANDBY: Output available with varying load for the duration of the interruption of the normal source power. Average power output is 70% of the standby power rating. Typical operation is 200 hours per year, with maximum expected usage of 500 hours per year.

RATINGS: Ratings are based on SAE J1349 standard conditions. These ratings also apply at ISO 3046 standard conditions.

DEFINITIONS AND CONDITIONS

¹ For ambient and altitude capabilities consult your Cat dealer. Air flow restriction (system) is added to existing restriction from factory.

² Generator temperature rise is based on a 27°C ambient per NEMA MG1-32.

* Governing Class capability as per ISO8528-5. Consult your local Cat dealer for configuration and site specific transient performance classification.

LET'S DO THE WORK.™

www.cat.com/electricpower

©2024 Caterpillar
All rights reserved.

Materials and specifications are subject to change without notice.

The International System of Units (SI) is used in this publication. CAT, CATERPILLAR, LET'S DO THE WORK, their respective logos, "Caterpillar Corporate Yellow" the "Power Edge" and Cat "Modern Hex" trade dress as well as corporate and product identity used herein, are trademarks of Caterpillar and may not be used without permission.