

Cat® DE350S GC

Diesel Generator Sets



Standby: 60 Hz



Image shown may not reflect actual configuration

Engine Model	Cat® C9.3B In-line 6, 4-cycle Diesel
Bore x Stroke	115 mm x 149 mm
Displacement	9.3 L
Compression Ratio	16.5:1
Aspiration	Turbocharged Air-to-Air Aftercooled
Fuel Injection System	Common Rail
Governor	Electronic ADEM™ A6 - G3 Class* capable

Model	Standby	Emission Strategy
DE350S GC	350 ekW (437.5 kVA)	Low BSFC

PACKAGE PERFORMANCE

Performance	Standby
	60 Hz
Genset power rating, kVA	437.5
Genset power rating with fan @ 0.8 power factor, ekW	350
Emissions	Low BSFC
Performance number	EM5664
Fuel Consumption	
100% load with fan, L/hr (gal/hr)	90.4 (23.8)
75% load with fan, L/hr (gal/hr)	68.5 (18.1)
50% load with fan, L/hr (gal/hr)	48.4 (12.7)
25% load with fan, L/hr (gal/hr)	28.7 (7.5)
Cooling System¹	
Radiator air flow restriction (system), kPa (in. water)	0.125 (0.5)
Radiator air flow, m ³ /min (cfm)	561.4 (19825.7)
Total coolant capacity, L (gal)	34 (8.98)
Inlet Air	
Max. combustion air intake restriction, kPa (in. water)	6.2 (24.9)
Combustion air inlet flow rate, m ³ /min (kg/hr)	25.1 (887)
Exhaust System	
Exhaust stack gas temperature, °C (°F)	522 (972)
Exhaust gas flow rate, m ³ /min (cfm)	70.2 (2478.2)
Exhaust system back pressure (minimum allowable), kPa (in. water)	8 (32.1)
Exhaust system back pressure (maximum allowable), kPa (in. water)	12 (48.2)
Heat Rejection	
Heat rejection to jacket water, kW (Btu/min)	140 (7940)
Heat rejection to exhaust (total), kW (Btu/min)	340 (19352)
Heat rejection to aftercooler, kW (Btu/min)	81.8 (4653)
Heat rejection to atmosphere from engine, kW (Btu/min)	25.5 (1449)
Heat Rejection²	
NOx, mg/Nm ³ (g/hp-hr)	2871.2 (5.81)
CO, mg/Nm ³ (g/hp-hr)	287 (0.58)
HC, mg/Nm ³ (g/hp-hr)	21.5 (0.05)
PM, mg/Nm ³ (g/hp-hr)	7.4 (0.02)

Alternator ³	60 Hz				
	Voltages	480V	440V	220V	380V
Motor starting capability @ 30% Voltage Dip, skVA	1099	922	922	691	1099
Current, Amps	526	574	1148	596	1052
Genset Rating, ekW	350	350	350	313.9	350
Frame Size	A2925L41				
Excitation	S.E				

WEIGHTS & DIMENSIONS

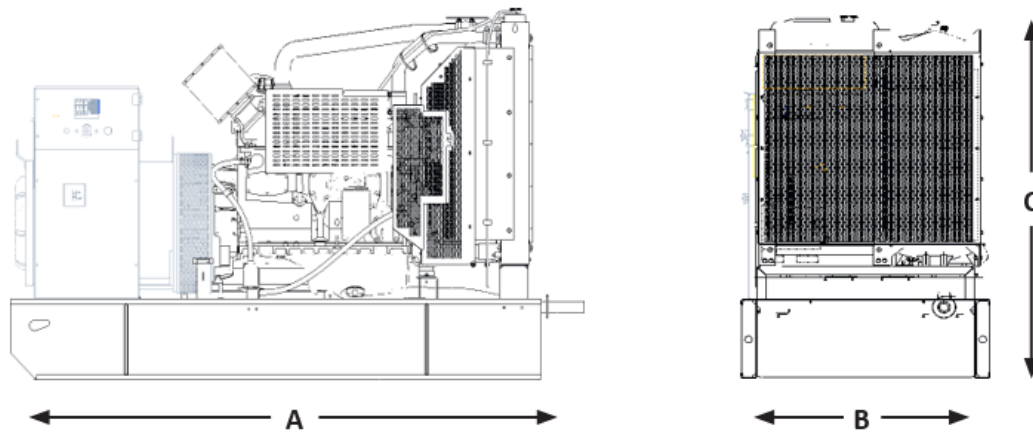

Length "A" mm (in)	Width "B" mm (in)	Height "C" mm (in)	Dry Weight kg (lb)
2640 (103.9)	1160 (45.6)	1770 (69.6)	2358 (5198.5)

Note: General configuration not to be used for installation. See general dimension drawings for detail.

APPLICABLE CODES AND STANDARDS:

AS1359, IEC60034-1, ISO3046, ISO8528, NEMA MG1-33, EAC,CE,UKCA.

Note: Codes may not be available in all model configurations. Please consult your local Cat Dealer representative for availability.

STANDBY: Output available with varying load for the duration of the interruption of the normal source power. Average power output is 70% of the standby power rating. Typical operation is 200 hours per year, with maximum expected usage of 500 hours per year.

RATINGS: Ratings are based on SAE J1349 standard conditions. These ratings also apply at ISO3046 standard conditions

DEFINITIONS AND CONDITIONS

¹ For ambient and altitude capabilities consult your Cat dealer. Air flow restriction (system) is added to existing restriction from factory.

² Emissions data measurement procedures are consistent with those described in EPA CFR 40 Part 89, Subpart D & E and ISO8178-1 for measuring HC, CO, PM, NOx. Data shown is based on steady state operating conditions of 77°F, 28.42 in HG and number 2 diesel fuel with 35° API and LHV of 18,390 BTU/lb. The nominal emissions data shown is subject to instrumentation, measurement, facility and engine to engine variations. Emissions data is based on 100% load and thus cannot be used to compare to EPA / EU regulations which use values based on a weighted cycle.

³ Generator temperature rise is based on a 40° C ambient per IEC60034-1.

* Governing Class capability as per ISO8528-5 for 60 Hz application only. Consult your local Cat dealer for configuration and site specific transient performance classification.

www.cat.com/electricpower

©2025 Caterpillar
All rights reserved.

Materials and specifications are subject to change without notice.

The International System of Units (SI) is used in this publication. CAT, CATERPILLAR, LET'S DO THE WORK, their respective logos, "Caterpillar Corporate Yellow" the "Power Edge" and Cat "Modern Hex" trade dress as well as corporate and product identity used herein, are trademarks of Caterpillar and may not be used without permission.